

Review

Post-translational non-enzymatic modification of proteins
II. Separation of selected protein species after glycation and other
carbonyl-mediated modifications

Ivan Mikšík*, Zdeněk Deyl

Institute of Physiology, Academy of Sciences of the Czech Republic, Vídeňská 1083, CZ 142 20 Prague 4, Czech Republic

Abstract

There are two strategies applicable to revealing non-enzymatic post-translational modifications of proteins; while assaying of the hydrolytically stable adducts was the subject of our previous communication [1], here we attempted to review separation technologies for the unfragmented modified proteins. There are a few standard procedures used for this purpose, namely Laemmli gel electrophoresis, different modes of gel permeation chromatography and boronate affinity chromatography. The latter approach makes use of the vicinal hydroxy groups present in glycated proteins. Some (but not all) arising adducts exhibit typical fluorescence which can be exploited for detection. In most cases fluorescence is measured at 370/440 nm for the so-called advanced glycation products or at 335/385 nm for the only so far well characterized glycation marker (pentosidine). Some indication exists that, e.g., synchronous fluorescence detection will probably in the future add to the selectivity and allow the distinction of the different adducts arising during non-enzymatic post-translational modifications (glycation). The proteins reviewed are serum albumin, collagen and lens proteins while glycation of hemoglobin is the subject of another review within the present volume. © 1997 Elsevier Science B.V.

Keywords: Reviews; Proteins

Contents

1. Strategies for glycated protein analysis and/or preparation	312
1.1. Boronate affinity chromatography	313
1.2. Polyacrylamide gel electrophoresis (PAGE)	313
1.3. Size exclusion chromatography	313
1.4. Anion-exchange HPLC	314
1.5. Chromatofocusing	315
1.6. Facts to be remembered during modified protein separation	315
2. Serum albumin	316
2.1. General and sample treatment	316
2.2. Affinity chromatography using <i>m</i> -aminophenylboronate columns	316
2.2.1. Simple single column separations	316
2.2.2. Protocol for two column boronate affinity assay of glycated albumin	318
2.2.3. Protocol for affinity chromatography on Glycogel B	318

*Corresponding author.

2.2.4. High-performance liquid affinity chromatography	319
2.3. Separations of albumin, non-specific with regard to glycation	319
2.3.1. Reversed-phase chromatography	319
2.3.2. Separation of albumin with immobilized dyes	320
2.4. Other methods for following albumin glycation	320
2.5. Some additional features of albumin glycation	320
2.6. Albumin microheterogeneity due to fatty acids binding and glycation	321
2.7. Pyridoxal-5'-phosphate adducts	322
3. Collagen	322
3.1. Sample solubilisation and general	322
3.2. Preparation of collagen CNBr peptides ¹	323
3.3. Chromatographic conditions for collagen CNBr peptide separation	324
3.4. SDS-polyacrylamide gel electrophoresis of CNBr peptides	324
3.5. Separation of parent collagen α -chains	324
3.6. Collagen glycation in vitro	325
3.7. Collagen glycation in vivo	326
3.8. Collagen-lipoperoxidation adducts	328
3.9. Separation of glycated adducts from physiologically occurring cross-links	328
4. Lens proteins	329
4.1. Sample solubilization and general	329
4.2. Glycation adducts, carbamylated crystallins and products of oxidative modification	329
4.3. Adducts and polymerization reactions related to interactions with ascorbic acid	331
4.4. Pentosidine related cross-linking	333
4.5. Fructose derived adducts	335
4.6. Adducts with methylglyoxal	335
4.7. Acetylated crystallins	336
4.8. Glycation of lens membrane proteins	337
5. Lipid peroxy radicals and dityrosine crosslinking	337
6. Glycation of other proteins	338
7. Conclusions	343
Acknowledgements	343
References	343

1. Strategies for glycated protein analysis and/or preparation

Both in vitro and in vivo glycation lead either to polymerized protein species or to monotopic (non polymerized) protein molecules. In order to reveal the presence of protein polymers or modified (with blocked free amino group) molecules a number of separation techniques are applicable. To reveal the polymerized species, perhaps gel electrophoresis or some type of gel permeation chromatography can be used. Monotopic modifications can be discerned by ion-exchange chromatography or some of the focusing methods (chromatofocusing, isoelectric focusing). Affinity chromatography methods are also

applicable, mainly because in some cases glycation results in the preservation, at least of parts, of the sugar molecule thus offering the possibility to reveal the modified protein by exploiting the reactivity of vicinal hydroxy groups of the sugar moiety.

The general strategy applicable to both in vivo and in vitro non-enzymatically modified proteins has been recently reviewed by Wu et al. [2] using glycated serum albumin as the model protein. In this paper emphasis is put upon the polymerized entities. However, polymerized molecules represent usually only a fraction of the modifications which have occurred in the protein; some authors even believe that the monotopic (non-polymerizing) modifications predominate. In this review we limit ourselves to the assay of modified protein molecules (both polymerized and non-polymerized). A number of the arising adducts (some of them are even hydrolytically stable) can be revealed directly after protein

¹ For the nomenclature of cyanogen bromide released peptides of collagen type I and III see [50].

fragmentation. Separation methods used for assaying such adducts were the subject of our previous review [1].

As far as the modified proteins are concerned, we have focused upon serum albumin, collagen and crystallin because glycosylated hemoglobin assay (perhaps the most widespread analysis of a glycosylated protein) has been deferred to a special review in this volume.

1.1. Boronate affinity chromatography

This approach is widely used, and commercially available kits help its popularity, (e.g., for glycosylated albumin assay, see the respective section of this review). Large affinity columns can be also prepared in house from *m*-aminophenylboronated agarose to obtain sufficient quantities of glycosylated proteins for, e.g., fluorescence measurements. The reason is that commercial kits usually work with minute sample (and protein) amounts not sufficient for measuring, e.g., fluorescence spectra. A buffer usually containing 0.25 M ammonium acetate, 0.05 M magnesium chloride (and 0.5% phenoxyethanol), pH 8.5 (or 8.0) is used for sorbent equilibration and elution of non-glycosylated species. The bound (glycosylated proteins) are usually eluted with 0.1 M Tris–HCl buffer containing 0.2 M sorbitol (and 0.5% phenoxyethanol), pH 8.5. After the majority of bound proteins is eluted, 0.5% acetic acid is used to regenerate the column and to elute the more tightly bound protein species. Attempts for preparation more efficient phenylboronate sorbents (pressure resistant) can be witnessed repeatedly in the literature. This technique is reasonably independent of the protein molecule involved as the affinity interaction regards only the reacted sugar residue. Because the separation mechanism is based on the recognition of vicinal diol groupings, enzymatically glycosylated proteins (glycoproteins) may be the source of interferences.

1.2. Polyacrylamide gel electrophoresis (PAGE)

This is used (i) to reveal charge changes in non-polymerized protein species by comparing the results obtained in the absence of SDS and (ii) to reveal the molecular mass of polymerized protein species (in the presence of SDS). No special separation pro-

cedures are needed for this purpose, in most cases some modification of the classical approach of Weber and Osborn is used [3]. The samples containing 20–25 μg of protein after mixing with an equal volume of 2-fold diluted sample buffer (125 mM Tris–HCl, 4% SDS, 20% glycerol, 10% dithiothreitol and 0.01% bromphenol blue, pH 6.8) are boiled for 5 min and then applied on top of the gel. The tank buffer consists of 25 mM Tris, 192 mM glycine and 0.1% SDS, pH 8.3. Typically, the procedure is materialized in the slab gel version by the commonly used procedure of Laemmli [4] (Fig. 1). Regarding detectability of glycosylated protein species it has to be stressed that glycosylated proteins with a higher proportion of OH groups show a better stainability in the silver staining method as compared to their non-glycosylated counterparts [5,6]. Characteristic polyacrylamide gel profiles and their comparison is seen from Figs. 2 and 3.

1.3. Size exclusion chromatography

Size exclusion chromatography is frequently used to reveal changes of protein molecular mass during post-translational modifications (mainly polymerization). Superose 6 HR is a typical sorbent used for this purpose. A buffer consisting of 0.05 M phosphate and 0.15 M sodium chloride pH 6.8 can be used both for column equilibration and elution. The flow-rate should be about 0.5 ml/min; the eluate can be monitored either by UV (280, 220 nm) or by 370/440 nm fluorescence. This, of course, is used to reveal (and prepare) the high molecular mass species rather than for analytical purposes. Another approach to reveal the highly polymerized molecules is by Sepharose CL-4B chromatography. The column used should be about 2.6 \times 60 cm, 300 ml content; buffer containing 0.01 M phosphate pH 7.2 is used both for equilibration and elution; 2 ml of the glycosylated incubation mixture are applied to the column operated at an elution rate of 20 ml/h. Either absorbance or fluorescence can be used for detection. Because the separation efficiency of this approach is not very high, usually only three fractions, namely with no fluorescence, medium and high fluorescence, are collected. For preparative purposes individual fractions are dialyzed against, e.g., saturated ammonium

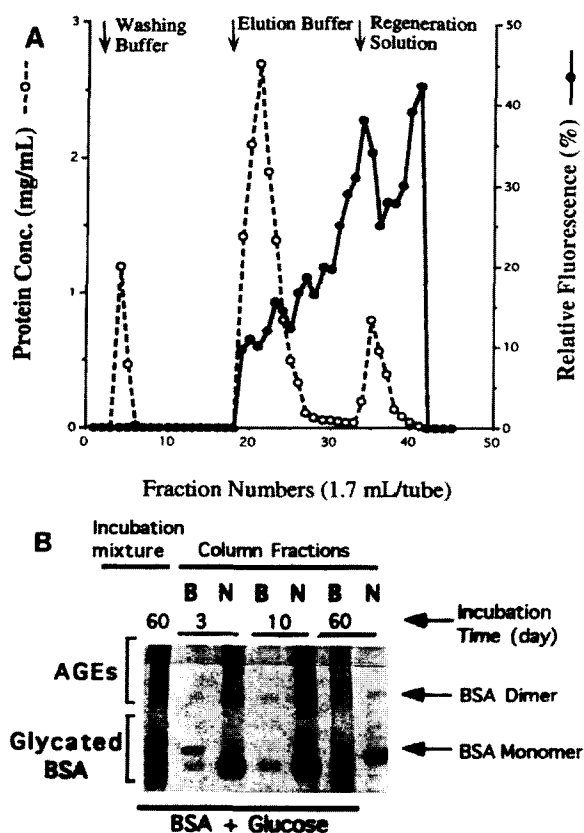

Fig. 1. Boronate affinity chromatography of an incubation mixture of bovine serum albumin and glucose. A, Elution profile of affinity chromatography. The first protein peak (nonbound fraction), eluted by the washing buffer represents the nonglycated albumin, the second protein peak (bound fraction) is the glycated portion of albumin molecule and the third peak (with the highest AGEs associated fluorescence) should be the AGE-albumin which could be eluted only by regeneration solution. B, 10% PAGE analysis of bound (B) and unbound (N) albumin fractions. Reprinted from Wu et al. [2] by permission of John Wiley and Sons.

sulphate and the precipitate is redissolved in 0.01 M phosphate buffer pH 7.2 before further treatment.

1.4. Anion-exchange HPLC

Most of the strong anion-exchangers can be used. In Ref. [2] Hydropore AX 83-603-ETI (Rainin, Woburn, MA) prepacked column was used with 0.01 M phosphate buffer at pH 7.1 (the buffer used for dialysis after being made 1.0 M with respect to NaCl

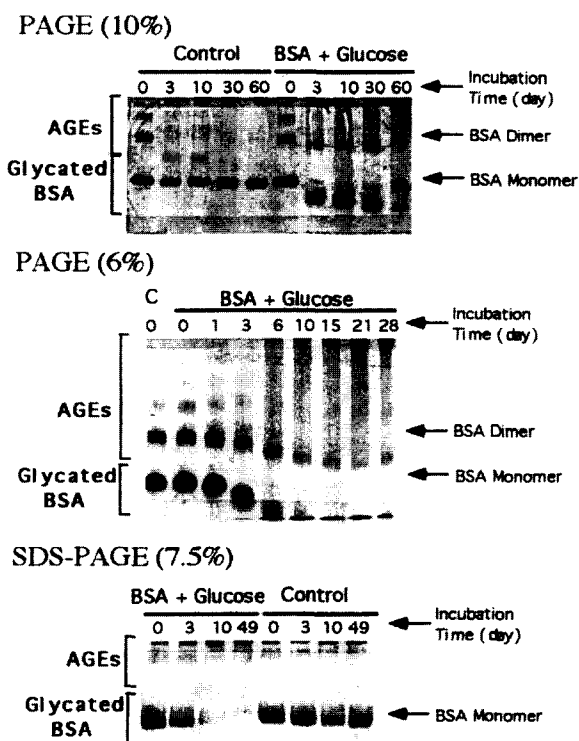

Fig. 2. Comparison of electrophoretic separations of glycation products of albumin and glucose in the absence and presence of SDS. Reprinted from Wu et al. [2] by permission of John Wiley and Sons.

can be used also for elution). The dialysis step prior separation is in this case inevitable and all samples should be briefly centrifuged before loading (the injected volumes range between 100–180 ml). The column is washed for 42 min with the equilibration buffer and eluted with a buffer containing 0.01 M phosphate and 1 M sodium chloride pH 7.1. The flow rate is maintained at 0.5 ml/min and the eluate is monitored either by absorbance or fluorescence. In comparison with size exclusion chromatography this approach should distinguish polymerized and non-polymerized species as well as the non-polymerized monotonically modified species that behave differently compared to their non-glycated counterparts due to the free amino groups blockade.

DEAE Sephacel chromatography is carried out at 4°C on, e.g., a Pharmacia column (K 9/15 or 0.9×15 cm) containing 9 ml DEAE Sephacel; a linear gradient of NaCl from 0 to 0.5 M in the equilibrium

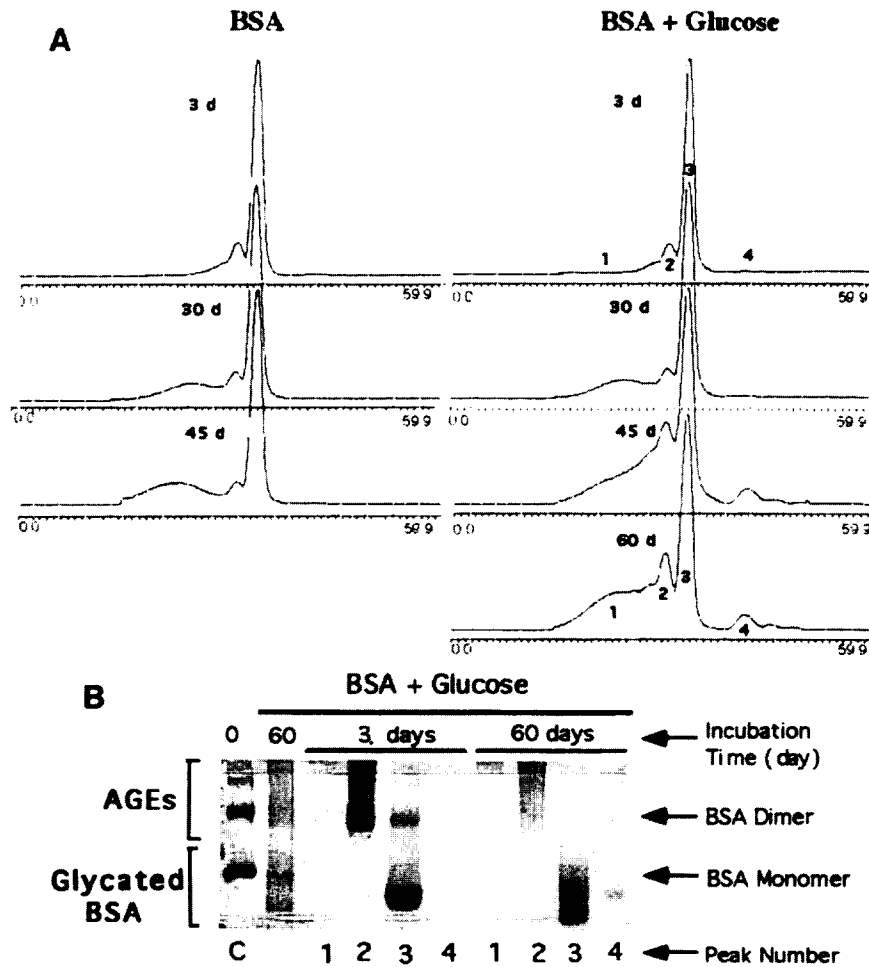

Fig. 3. Comparison of size-exclusion HPLC (Superose 6 HR) (A) and PAGE analysis (B) of glycated albumin. Reprinted from Wu et al. [2] by permission of John Wiley and Sons.

buffer (0.01 M phosphate, pH 7.2, 4°C) is used for protein elution.

1.5. Chromatofocusing

A Pharmacia FPLC column (5/5 HR, 0.92 ml bed column) packed with Pharmacia PBE 94 gel was used in the quoted paper [2] over the pH range 7–4. For column equilibration and sample dialysis an imidazole containing (0.025 M) buffer pH 7.1 can be used. All specimens after dialysis were filtered through a 0.2 µg centrifuge filter tube to remove any particles before HPLC separation. Polybuffer 94-HCl is recommended for elution after being diluted 8

fold and adjusted to pH 4. At the end of elution 1 M NaCl aqueous solution is used to wash out any protein remaining in the column. The flow-rate is maintained at 0.5 ml/min.

1.6. Facts to be remembered during modified protein separation

There are several points that one has to bear in mind with any research or assay related to non-enzymatic protein modifications.

1. The monotonically modified but not crosslinked

- species exhibit a larger specific charge due to the blockade of free amino groups and move in PAGE without SDS more rapidly to anode than their modified counterparts.
2. The polymerized species always represent a poly-component mixture which makes smears with low mobility under SDS polyacrylamide gel separation.
 3. The recovery upon phenylboronate affinity chromatography reveals (particularly in vitro modified protein samples) the presence of highly bound polymeric species which are so far only poorly characterized.
 4. The above approaches were applied to reveal the occurrence of glycosylated serum albumin; however with slight buffer composition modifications the same techniques can be used for other modified proteins as well.
 5. Harsher conditions of in vitro incubation with, e.g., glucose or other reducing sugars affect the majority of lysines present in the molecule including the free N-terminal amino group. The modifications observed are non-specific.
 6. Under in vivo conditions only a limited number, perhaps sterically more easily accessible amino groups, are affected and modified.
 7. Under in vivo conditions glycosylated proteins can be found in many different tissues [7] and there is a wide number of proteins that can be affected (see Fig. 4).

2. Serum albumin

2.1. General and sample treatment

The set of analytical methods used for the analysis of glycosylated serum albumin is more or less identical with that used for glycosylated hemoglobin and the same kits are used for this purpose (for review see Franzen, this Special Volume [157]). Both with human and bovine serum albumin there is virtually no possibility of obtaining an unglycosylated sample as even purified commercial preparations are always partly glycosylated. In human albumin the principal glycosylation site is lys 525 accounting for about 33% of the overall glycosylation; in bovine serum albumin glycosylation was shown to occur in the peptide se-

quence covering the region 548–557. The most likely residue to be glycosylated is lys 548, however it accounts for less than 20% of the modified lysine residues [8].

Regarding established methods for glycosylated albumin assay in most diverse matrices one can mention boronate affinity chromatography (aminophenylboronic acid columns available, e.g., from Pierce, Rockford, IL) [9,10], boronate agarose gels or slight modifications of this methodology are reported in Ref. [2,11] which can be used for simultaneous assessment of glycosylated albumin and hemoglobin. Separations by cation-exchange chromatography (SP 5PW, ToyoSoda, Ref. [12]), require tedious sample preparation, particularly if the glycosylated species should be analysed in urine [13].

As far as the non-chromatographic methods are concerned the fructosamine assay appears very popular along with the thiobarbituric test [12] and ELISA method [14]. It is interesting to note that glycosylated albumin induces collagen type IV excretion of mesangial cells [9]. This is the first indication to our knowledge that glycosylated proteins can enter the cell metabolism and modify it and that their effect is not limited to the changes of physico-chemical properties of the already synthesized protein. Electrophoretic separations (according to Laemmli) in combination with boronate affinity chromatography after ^3H borohydride reduction of the adducts were used for comparative studies of hemoglobin, albumin and human platelet proteins glycosylation [15].

Contrary to the generally accepted idea about polymerization, and consequently increased stabilization of glycosylated protein molecules, nonenzymatically glycosylated serum albumin after in vitro incubation with ferric ions at 37°C in 0.2 M phosphate buffer liberates after 30 days under sterile conditions a low molecular fraction rich in tyrosine and phenylalanine [16].

2.2. Affinity chromatography using *m*-aminophenylboronate columns

See Ref. [17].

2.2.1. Simple single column separations

(a) Determination in serum: serum (50 μl) is diluted 4-fold with elution buffer for non-glycosylated

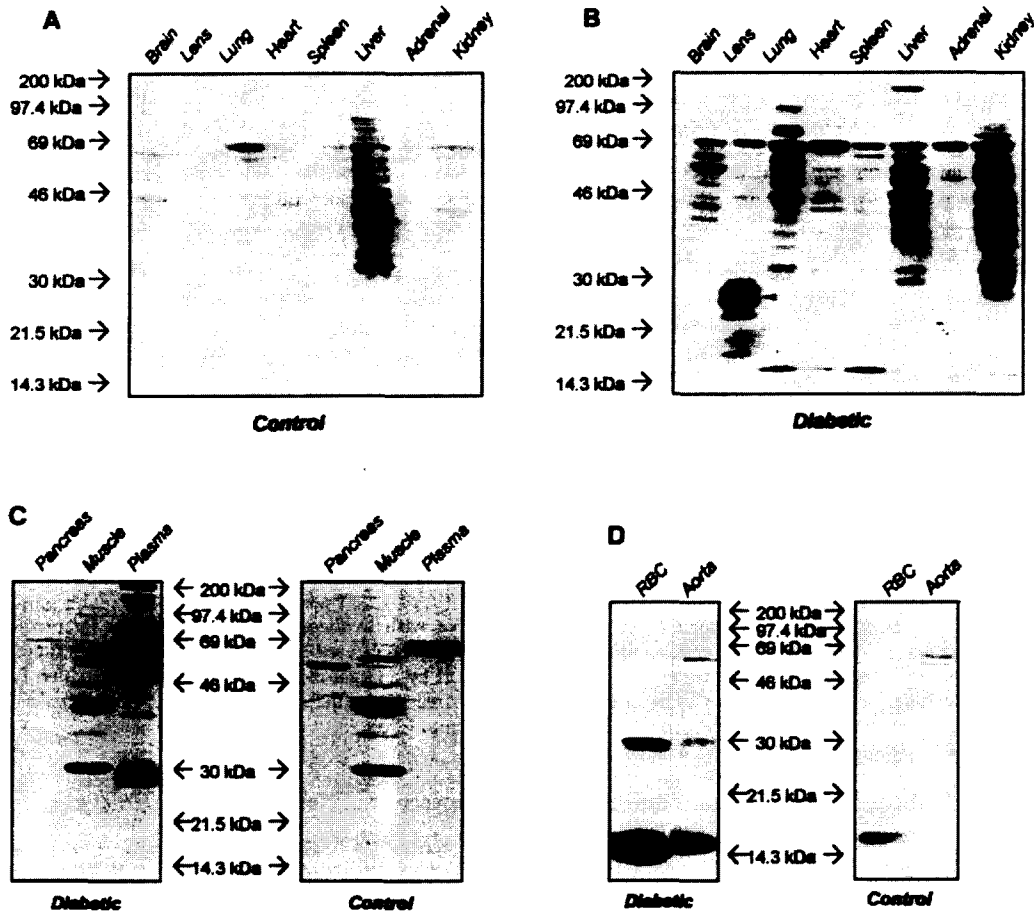

Fig. 4. Detection of glycosylated proteins in various tissue extracts by immunoblotting (with a polyclonal hexitol-lysine antibody). 12.5% SDS-PAGE analysis of control rats (A) and streptozotocin-induced diabetic rats (B) (arrowhead, lens crystallins). Immunoblot of pancreas, muscle and plasma (C) of 12.5% SDS-PAGE analysis and immunoblot of RBC (hemolysate of red blood cell) and aorta (D) at 15% SDS-PAGE. Reprinted from Myint et al. [7] with permission.

fraction (EB-NG) (500 mg/l bovine serum albumin, 250 mmol/l ammonium acetate, 50 mmol/l magnesium chloride, 0.4 g/l sodium azide, pH adjusted with 5 mol/l NaOH to 8.5) and is applied to the Glyco-Gel column (a part of the test kit, Pierce and Warriner, Chester, UK) equilibrated with the wash buffer (EWB) which is the same buffer as EB-NG except that it does not contain bovine serum albumin. Then 800 μ l EB-NG is drained through the column, a further 14 ml is passed through the column (15 ml total) to ensure elution of the non-glycosylated species. The glycosylated fraction is eluted with 3 ml of EB-G which is essentially EB-NG which

contains 200 mmol/l sorbitol. Column fractions are evaluated by radioimmunoassay, for clinical purposes glycosylated albumin is expressed as percentage of the total albumin in serum.

(b) Determination in urine. Ultrafiltered urine is diluted 5-fold with EB-NG (4 ml), 1 ml of this solution is applied to the Glyco-Gel column (equilibrated with EWB), followed by 5 ml of EB-NG elution. The elution of the non-glycosylated species is completed by another portion of 10 ml of the EB-NG buffer and the glycosylated albumin fraction is released by 3 ml of the EB-G buffer. Column fractions are evaluated by radioimmunoassay.

Column regeneration and storage requires adequate attention. Following the elution of the glycosylated fraction, the columns are eluted sequentially with 3 ml EB-G, 3 ml EWB, 5 ml of 100 mmol/l HCl and 5 ml of 1 mmol/l HCl in which they are stored. Before the re-use the columns are equilibrated with EWB. Separate columns should be used for serum and urine to prevent the possibility of trace amounts of serum albumin remaining on the column, to contaminate the comparatively dilute urine samples.

In Ref. [17] a detailed description of the optimization of the elution volumes of individual buffers and different sample types was presented. A comparison of different techniques was reported by Cohen [18], who, compared the results of HPLC [19], boronate affinity chromatography, electrophoresis on agarose gels [20] and monoclonal antibody based enzyme linked immunosorbent assay [15,21].

2.2.2. Protocol for two column boronate affinity assay of glycosylated albumin

The procedure, criticised in Ref. [18], for giving far too high results [19] runs as follows:

Asahipak ES-502N (100×7.6 mm column), an anion-exchange sorbent having an exclusion limit of 300 000 rel.mol. mass units (it acts simultaneously as a molecular sieve) of 9.0 μm particle size and Asahipak gel GS-520-boronate are used. The latter sorbent is activated with epichlorhydrin (80 g of the gel are suspended in 800 ml of dimethyl sulfoxide and 374 ml of epichlorhydrin is added followed by a 40 ml portion of 10 mol/l NaOH). The reaction mixture is stirred overnight, the activated gel is suspended in 100 ml water (40 g of the gel) and 26 g *m*-aminophenylboronic acid hemisulfate are added. The separation principle is evidently the same as in the above described boronate affinity chromatography with the commercial minicolumns and stepped elution.

As a matter of fact the elution system and automated pre-separation are the points where this approach differs from that described before. In this case two eluents are used. Eluent A is 5% ethanol containing 250 mmol/l ammonium acetate and 50 mmol/l magnesium chloride pH 8.5. Eluent B is 50 mmol/l solution of EDTA disodium salt with 100

mmol/l Tris and 200 mmol/l sorbitol (pH 8.5). Two columns in series are used and the overall arrangement of the system is seen in Fig. 5; first column is packed with the molecular sieving properties exhibiting ion-exchange properties, the other column works in the boronate-affinity mode. During separation both columns are thermostated at 30°C. A 10 min convex gradient program from eluent A to 70% eluent B is started after injection of 5 μl of the sample. The effluent is passed through a fluorescence monitor (Detector I, 285/340 nm). After the first fraction has drained off, the fraction containing albumin is introduced into the Asahipak GS 520 boronate column through a high pressure valve. The effluent from the second column passes through a second fluorescence monitor; the first peak in this recording represents the non-glycosylated species, while the second peak was shown to be glycosylated albumin. The third minor peak seen in the second chromatography is probably IgG. The nature of the glycosylated fraction was verified by radioimmunoassay. Surprisingly there is no reference to setting up the wavelengths of the second fluorescence detector. If the same parameters as with the first one were used (285/340) then the profile refers to tryptophan/tyrosine recovery and is unrelated to glycosylation arising fluorescent products.

The criticism of Cohen [18] is justified, perhaps, as far as the interpretation of results is concerned, but from the chromatographic point of view (the system set up) the procedure of Shima et al. [19] is quite a smart alternative.

2.2.3. Protocol for affinity chromatography on Glycogel B

See Ref. [21].

Prepacked microcolumns of 3-amino-phenylboronic acid immobilized on agarose (Glycogel B, Pierce, Rockford, IL) are used for this purpose. The columns are equilibrated with 0.25 M ammonium acetate (pH 8.0) containing 0.05 M MgCl₂ after application of 2 mg human serum albumin, 20 ml of the same buffer is passed through the column. The bound (glycosylated) albumin is eluted with 5 ml of 0.2 M sodium citrate (see also Section 1).

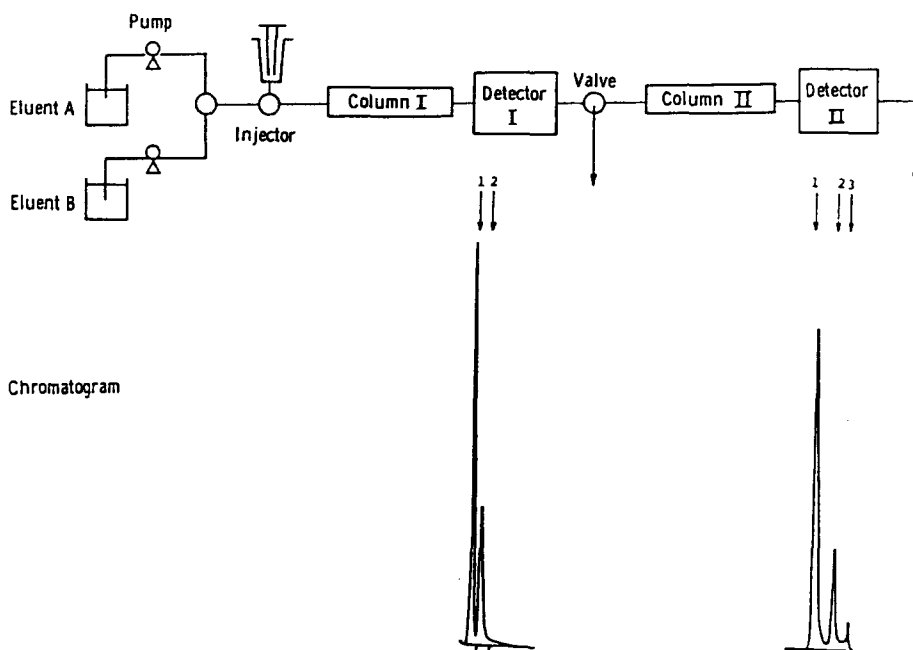

Fig. 5. Schematic diagram of the two column chromatographic assay of glycated albumin. Column I, an anion-exchange column, separates albumin (peak 2 in the first chromatogram) and column II, an affinity boronate column, separates glycated albumin (peak 2 in the second chromatogram). Reprinted from Shima et al. [19] by permission of Springer.

2.2.4. High-performance liquid affinity chromatography

Koyama and Terauchi [22] introduced a new boronic acid-immobilized porous polymer packing material for separation of glycated proteins, namely albumin. Polymer porous material (composed from 2,3-dihydroxypropylmethacrylate monomer, poly(oxyethylenedimethacrylate) and dipentaerythritolhexaacrylate as cross-linkers) was activated with 1,1'-carbonyldiimidazole and as affinity ligand was coupled to *m*-aminophenylboronic acid hemisulfate. Separation procedure for blood proteins was as follows: After application of sample (20 μ l) to the column (150 \times 4 mm) sample was eluted with eluent I (0.2 M ammonium acetate, 0.1 M MgCl₂, pH 9.0) for 10 min to elute non-glycated proteins, glycated proteins were eluted by acidic eluent II (0.2 M ammonium acetate, pH 5.5) for 10 min and finally the column was washed by eluent III (0.01 M HCl) for another 10 min. Flow-rate was 1.0 ml/min and elutions were monitored at 280 nm. This method is

usable for quantitation of glycated serum albumin in, e.g., diabetes mellitus.

2.3. Separations of albumin, non-specific with regard to glycation

2.3.1. Reversed-phase chromatography

Aquapore sorbent RP 300 (Brownlee, Santa Clara, CA) can be used for this purpose (200 \times 4.6 mm column) [21]. The column is equilibrated with 50–70% formic acid containing 0–20% isopropanol. The best resolution can be obtained by using two columns in series after equilibration with 60% formic acid containing 6.5% isopropanol. Elution is done with a concave gradient using 60% formic acid as buffer A and 60% formic acid containing 10% isopropanol as buffer B (0 min 65% B; 5 min 75% B; 20 min 77% B; 25 min 80% B; 30 min 100% B; 40 min 100% B; 40.1 min 65% B – washing and reequilibration). The results obtained are in Fig. 6. Fractions I, II and III represent albumin hetero-

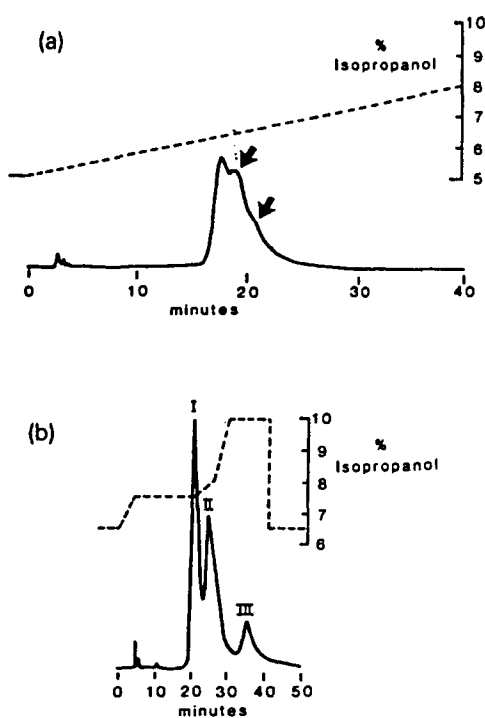

Fig. 6. RP-HPLC of native albumin with one column (a), flow-rate 1 ml/min and two-column system (b), flow-rate 0.8 ml/min; for gradient conditions of isopropanol see figure inserts. Detection at 280 nm. Fractions I, II and III are individual components of albumin, not separated glycated and non-glycated albumin (reflect heterogeneity of albumin). Reprinted from Vidal et al. [21] with permission.

geneity and are unrelated to glycated and non-glycated albumin; glycated albumin has to be assayed in individual fractions by another method.

2.3.2. Separation of albumin with immobilized dyes

Non-specific separations can also make use of chromatography on Blue Sepharose (0.3 ml serum applied elution with 0.05 M Tris-HCl buffer, pH 7.0, containing 0.1 M NaCl changed to the same buffer containing 1.5 M NaCl to elute the bound albumin fraction; 8 ml of the first buffer are needed), DEAE Affigel Blue, CM Affigel Blue (operated under similar conditions as described above) or chromatography on coupled columns of Red Sepharose and Blue Sepharose (washed with 25 ml of the 0.05 M Tris-HCl buffer pH 7.0, containing 0.1 M NaCl at a flow-rate 20 ml/h) can be used as well.

The main disadvantage of these methods is that they are capable of separating the albumin fraction from the rest of serum proteins, however, they are unable to distinguish between the glycated and non-glycated species. Therefore the level of glycation is estimated in the eluted albumin fraction by, e.g., the phenol-sulphuric reaction [23,24]. Consequently these procedures can be recommended as prepurification steps only; for the very analysis more efficient methods like phenylboronate affinity chromatography have to be preferred.

2.4. Other methods for following albumin glycation

There are also other separation methods for the investigation (or follow up) of albumin glycation. One possibility is to use ^{14}C glucose and follow the level of radioactivity incorporated into the albumin fraction (very applicable for pharmacokinetic studies) [25] or agarose gel electrophoresis with nitroblue tetrazolium coloration [26], which, however, should be mentioned only for completeness as these are completely routine procedures uninteresting from the chromatographers point of view.

In clinical laboratories ELISA tests are successfully competing with the chromatographic and electro-migration assays of glycated albumin [27].

2.5. Some additional features of albumin glycation

Glycation of serum albumin has two specific features, so far not described with other proteins, though equally possible. The first of these is the evidence for non-enzymatic glycation of the serum albumin Amadori products. Briefly the evidence in this respect runs as follows:

When partially glycated bovine serum albumin was reincubated with sugars where de novo glycation was prevented by reductive methylation of amino groups, additional increase in fluorescence was observed. Some differences were observed in the rate of the reactions when glucose and fructose were used as protein modifiers, fructose being about 10 times faster in forming the adducts in the first step of glycation (fructation) [28]. It is interesting to note that luminescence was measured at 340/420 nm (on the contrary to the usual 370/440 nm, not commented on in the quoted paper). Generally there is

column and stepwise elution was started according to the following scheme: (1) washing of the unbound proteins with the starting buffer; (2) elution with a 0.35 mmol/l KCl solution containing 25 mmol/l Tris buffer; (3) elution with a 1.5 mol/l KCl solution containing 50 mmol/l Tris buffer; (4) elution with 2 mol/l urea; (5) elution with 6 mol/l urea. For reuse, the gel was washed with 20% ethanol followed by elution with five column volumes of the initial buffer. The elution with a particular solvent was changed when the absorbance at 280 nm dropped to less than 0.01. The degree of glycation was determined by a modified fluorimetric method. The fractionated albumin samples comprised three distinct classes: The first category (fractions 1, 2 and 3) had little if any affinity to the resin, with a high amount of bound fatty acids. The second category appeared mainly in fraction 5 which both in the degree of glycation and content of fatty acids corresponded to native albumin (obtained from healthy persons). The last category consisted of fractions 7 and 8 and showed various content of bound glucose and fatty acids, exhibited non-specific strong affinity to the resin and was considerably variable when samples of various diabetic patients were analyzed. Direct fluorescence measurement of the glycated fractions was sometimes hindered by intense fluorescence of the samples themselves; in these cases rechromatography over a DEAE cellulose column helped to remove the interference either by further purification of the albumin fraction and/or elimination of the fluorescent material.

As revealed in another paper, the lys 525 which is the primary target in albumin non-enzymatic glycation remains unaffected by the interaction of free fatty acids, indicating that the complex picture visualized by Cibacron Blue F3A chromatography is due to interactions simultaneously affecting several other domains of the albumin molecule [31].

2.7. Pyridoxal-5'-phosphate adducts

The covalent binding of pyridoxal-5'-phosphate is important in the regulation of metabolism of this vitamin. By incubating serum albumin with ^3H pyridoxal, reducing the sample with potassium borohydride and subjecting it to tryptic hydrolysis it was possible to determine lys 190 as the primary binding

site [32]. The tryptic peptides were separated first on a 0.46×25 cm Synchropak AX-300 anion-exchange column (Syn-Chrom, Lafayette, IN) using a 30 min linear gradient of 0.02 M to 0.5 M ammonium bicarbonate, pH 8.0, at a flow-rate 1.5 ml/min. Aliquots of the collected fractions were assayed for radioactivity, pooled and lyophilized. The lyophilized sample was dissolved in 0.5 ml of 25 mM ammonium bicarbonate and incubated for 1 h at 37°C with 6 µg of alkaline phosphatase to remove the phosphate group. The dephosphorylated peptides were subjected to a second step anion-exchange chromatography. The primary radioactive fractions from the second run were purified by reversed-phase chromatography using a 0.46×15 cm Zorbax ODS column (Dupont, Wilmington, DE) with a 10% to 50% acetonitrile gradient (0.1 to 0.0075% trifluoroacetic acid over 20 min at a flow-rate 1 ml/min). The radiolabeled peptides were subjected to sequencing in a gas phase protein sequencer.

3. Collagen

3.1. Sample solubilisation and general

Contrary to other proteins discussed in this review, collagen biosynthesis is a complex process characterized by (enzymatically precisely controlled) post-translational modifications [33]. These occur intracellularly and include hydroxylation of certain lysine and proline residues and enzymatically regulated glycosylation of some hydroxylysine residues. After the collagen is secreted from the cell, C- and N-terminal extension peptides are cleaved and tropocollagen molecules become stabilized by covalent cross-links into fibrillar arrays and networks. Nonenzymatic glycation of the free lysine ϵ -amino groups occurs in the extracellular space and follows the regular pathway in which the Amadori product plays a key role. As a matter of fact, collagen being a long-lived protein was one of the first studied in the context of non-enzymatic post-translational modifications.

There are basically three categories of post-translational glycation products present in collagen: carboxymethyl lysine, pentosidine and the so-called advanced glycation products (AGEs) which can be

revealed either by direct analysis (see our previous review, Ref. [1]) or by typical fluorescence (370/440 nm). Of course, diabetic conditions were the first studied in this respect [34] aside to aging changes where glycation of collagen seems to contribute to increasing collagen insolubility with advancing age [35]. As reported in [34], hydrogen peroxide appears to be involved in the Amadori product derived cross-links at least in vitro. Two hydroperoxides can be detected as chemiluminescent products by HPLC, though their formation was shown to occur under elevated temperature in vitro only; one of these compounds was identified as 3-hydroxy-5-hydroperoxy-2-methyl-5,6-dihydropyran-4-one, HMPD, pyrone hydroperoxide [36].

The first problem to be overcome in any analysis of glycated collagens is to bring this poorly soluble protein in solution. Most of the current discussion is related to collagen type I, as only scattered information is available about glycation of other collagen types [37–39].

As we have shown in our previous reports [40–43] based on the earlier investigation of Fietsch and Kühn [44], van der Rest et al. [45,46] and Miller et al. [47,48], a productive and reliable method of bringing tissue collagen (particularly types I, III and V) into solution is based on CNBr cleavage of this protein. The small number of methionine residues in the molecule results in a relatively limited number of cleavage products. Their distribution is unique for each type of collagen which provides a useful means for collagen type identification and structural analysis [41]. This strategy has been applied many times in the past for the identification of pathological collagens. The other way of bringing collagen into solution which has become a routine is limited pepsin digestion (for review see [49]).

The techniques used for separation of the resultant mixture of collagen CNBr peptides are both electromigration and chromatography. Ion-exchange chromatography, reversed-phase chromatography, gel electrophoresis and more recently also capillary electrophoresis have been used (for a brief survey of analytical strategies applied see, e.g., Ref. [42]). While ion-exchange separations yielded incomplete separations of complex CNBr mixtures and as a matter of fact were applicable to purified constituting α -chains of fibre forming collagens only, gel electro-

phoresis offered better resolution but at the expense of less reliable quantitation. At the present stage of knowledge there are only two strategies that can be successfully used for the separation of complex CNBr mixtures. Either some type of reversed-phase chromatography originally introduced by van der Rest et al. [45] or capillary electrophoresis in acidic buffers as described in our previous communications [41–43].

The profiles obtained both by reversed-phase HPLC and capillary electrophoresis were remarkably similar; this has been explained by assuming a similar separation mechanism of both these techniques in the particular case of fibre forming collagens. These proteins display a high internal homogeneity; consequently the bigger the CNBr released fragment, the larger its hydrophobic domain will be. Assuming further the hydrophobic interaction either with the reversed-phase packing (in case of HPLC) or bare silica capillary wall (in case of capillary electrophoresis), the larger CNBr peptides released from fibre forming collagens will come later in front of the detector's window. As a matter of fact most of the released CNBr peptides exhibit a linear relationship between retention (migration) time and their molecular mass [42,43].

Another fact that has to be respected with collagen proteins is the plethora of present (or supposedly present) modification products which are likely to stem not only from the glycation reactions, but may reflect lipid peroxidation processes as well (see Table 1, Ref. [40]). The compounds listed are only those which are known to exhibit distinct luminescence; the non-luminescent adducts are not paid attention here. In conclusion it can be said that we are dealing here with a complex mixture indeed, both as far as the peptides involved [33] but also as far as the arising adducts is concerned.

3.2. Preparation of collagen CNBr peptides

Collagen samples prepared either by established procedures [50] or purchased as commercially available products are treated with CNBr without collagen chain separation in 70% formic acid as described by

Table 1

Luminescence parameters of different products arising by post-translational modifications of amino groups. Reproduced from Deyl et al. [40] with modification

Products	Excitation (nm)	Emission (nm)	Reference
<i>(a) Products arising from interaction with reducing sugars</i>			
Pentosidine	335 (328)	385 (378)	[57] ([58])
Glycation related products	335 (328)	385 (378)	[59] ([58])
Advanced glycation end products	370	440	[35,60]
Fluorophore LM-1	360	460	[61]
3-Deoxyglucosone(glucose)/butylamine adduct FL-C	370	455	[62]
Glycated Amadori product (present in albumin)	340	420	[28]
Glucuronide derived product	350	410	[29]
<i>(b) Lipid peroxidation related products</i>			
Malondialdehyde/collagen adduct	390	460	[63]
Hydroxynonenal/collagen adduct	356	460	[63]
4,5(<i>E</i>)-epoxy-2(<i>E</i>)-decenal/butylamine adduct	350	430–440	[64]
4,5(<i>E</i>)-epoxy-2(<i>E</i>)-decenal/lysine	350	~395	[64]
4,5(<i>E</i>)-epoxy-2(<i>E</i>)-heptenal/butylamine adduct	360	~450	[64]
4,5(<i>E</i>)-epoxy-2(<i>E</i>)-heptenal/lysine adduct	350	430–450	[64]
13-hydroperoxy-9(<i>Z</i>),11(<i>E</i>)-octadecadienoic acid/butylamine adduct	350	440	[64]
13-hydroperoxy-9(<i>Z</i>),11(<i>E</i>)-octadecadienoic acid/lysine adduct	350	~450	[64]

Scott and Veis [51]. This procedure yields a considerable proportion of uncleaved peptides which emerge closely to the joint peak of $\alpha_1(\text{I})\text{CB}_7$ and $\alpha_1(\text{I})\text{CB}_8$; therefore in some experiments the reaction time should be increased up to 24 or repeated.

Peptide preparation directly from tissue slices can be done generally along the same procedure following incubation of the tissues in 0.2 M ammonium bicarbonate pH 7.0 containing 25% β -mercaptoethanol to reduce oxidized methionyl residues and thereby to enhance CNBr cleavage [52]. Lyophilized CNBr peptide preparations from tissue samples are redissolved in Milli Q water, centrifuged and lyophilized again; before analysis they are reconstituted either in formate buffer, 1% acetic acid or water at a concentration of 400 $\mu\text{g}/\text{ml}$ or otherwise as needed.

3.3. Chromatographic conditions for collagen CNBr peptide separation

See Ref. [40].

The sample (CNBr peptide mixture 30 mg) is dissolved in 0.5 ml 2% heptafluorobutyric acid (HFBA) and 20 μl are injected into the Supelcosil LC 304 (250 \times 4.6 I.D.) column. Elution is done by a linear gradient of: A, H₂O and B, 50% acetonitrile

(both containing 0.1% HFBA) from 30% B to 100% B at 60 min followed by 10 min isocratic washing with 100% B. The flow-rate is 0.1 ml/min and the column temperature is held at 60°C. The eluate is monitored by absorbance at 210 nm. This procedure yielded a profile shown in Fig. 8. Using a macroporous C₄ resin appeared superior to C₁₈ packings used in previous reports [53,54].

3.4. SDS–polyacrylamide gel electrophoresis of CNBr peptides

Separation of CNBr released collagen peptides follows the Laemmli procedure which may be slightly modified [6]. It is worth mentioning that glycosylated collagen zones are more distinctly stained than their non-glycosylated counterparts (Fig. 9), particularly if the silver staining technology is used.

3.5. Separation of parent collagen α -chains

Collagen constituting α -chains, their dimers and polymers can be obtained either by limited proteolytic (pepsin) cleavage of insoluble collagen and the presence of chain polymers may reflect, e.g., short-term in vitro incubation of monomeric α -chains with glucose. Methods for this separation involve

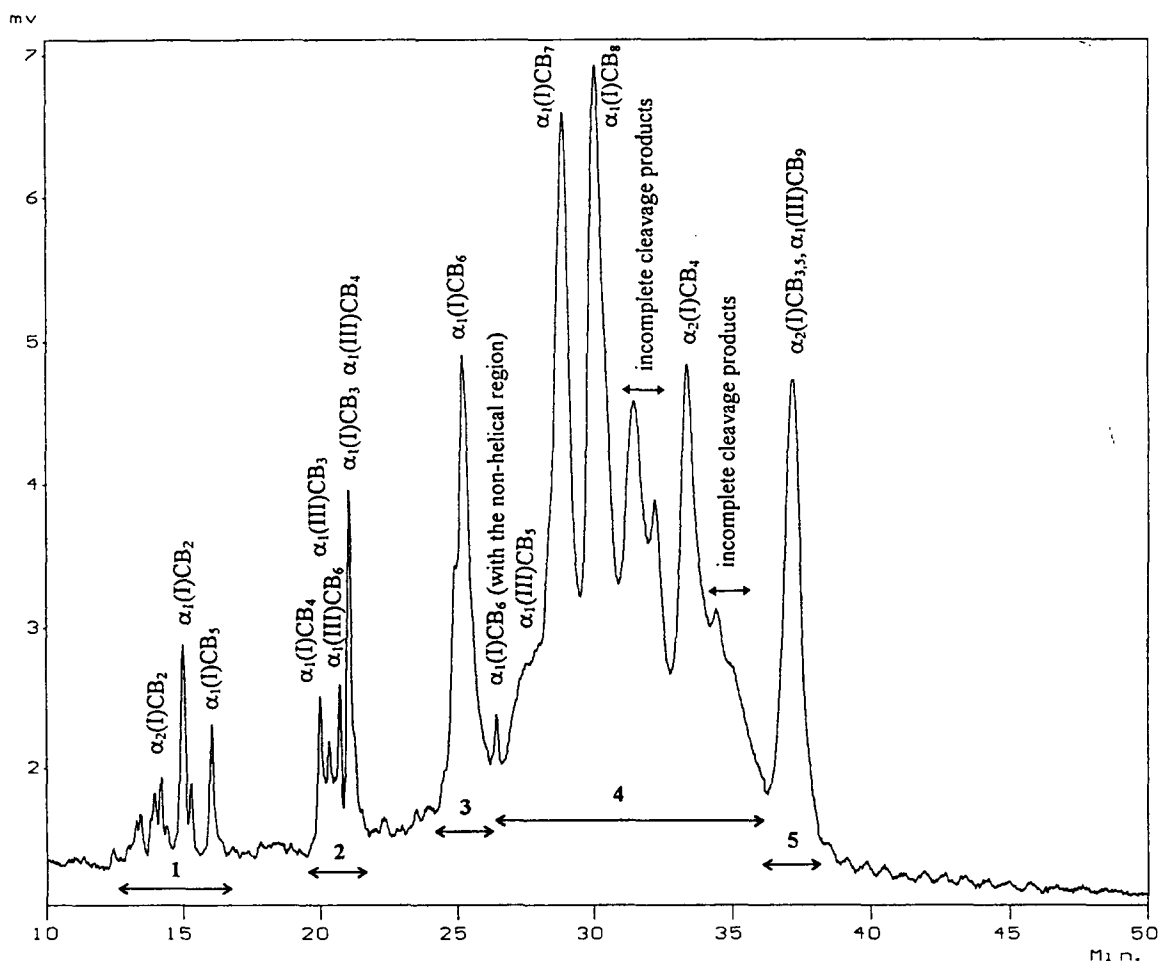

Fig. 8. HPLC profile of collagen CNBr peptides on macroporous C_4 resin. Reprinted from Deyl et al. [40].

most frequently CM cellulose chromatography or Sepharose CL-6B molecular sieving [55]. Briefly, for CM cellulose chromatography the salt precipitated collagen sample is dissolved in 0.5 M acetic acid, dialysed against 0.06 M sodium acetate buffer pH 4.8 (pepstatin is added to the dialyzing buffer), collagen is denatured by heating at 45°C for 30 min just before application to the column (Whatman CM-52, 1.5×10 cm). The sample is eluted with 600 ml of a linear gradient of NaCl (0–0.1 M) at 42°C and appropriate fractions (usually 5 ml) are collected. The effluent is monitored at short UV and/or fluorescence (if fluorescent adducts are to be monitored) (Fig. 10).

Further purification of each α (monomeric col-

lagen chain) and β component (chain dimer) can be materialized by using Sepharose CL-6B column (1.5×78 cm) with 0.05 M Tris–1 M $CaCl_2$, pH 7.5, buffer as mobile phase. The elution is monitored in the same way as mentioned above (Fig. 11).

3.6. Collagen glycation *in vitro*

As expected incubation of tail tendons from young rats with D-ribose results in the attachment of the sugar to the collagen molecule and subsequent cross-linking [55]. Also the fact that this reaction proceeds much faster with ribose than with glucose is not surprising. Ribose binds to all major CNBr peptides of collagen (as revealed by radioactivity measure-

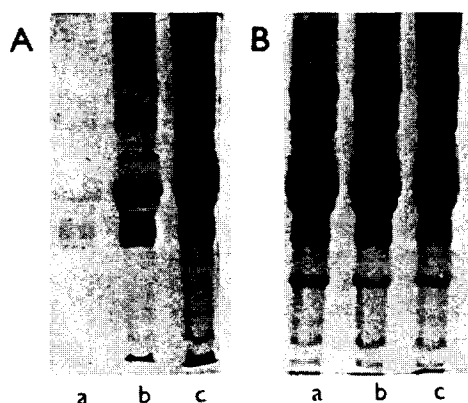

Fig. 9. Silver staining (A) and Coomassie Brilliant Blue R-250 staining (B) of SDS-PAGE electropherograms of acid-soluble collagen CNBr peptides incubated for 6 days in buffer alone (lane a), or in the presence of 100 mM glucose for 3 days (lane b) and for 6 days (line c). Reprinted from Hodny et al. [6].

ment using ^{14}C ribose) (Fig. 12), though some preference for the $\alpha_2(\text{I})\text{CB}_{3,5}$ and helical region of $\alpha_1(\text{I})\text{CB}_6$ was observed. Extensive pepsin digestion permitted isolation of dimers of α -chains cross-linked in triple helical regions which were identified as β_{11} , β_{12} and β_{22} components respectively. Some rather limited degree of heterogeneity of these

components was observed indicating that cross-linking occurred at several sites, some of which must be intermolecular (for details about collagen structure and relevant nomenclature see Refs. [50,55] and references therein). It was also shown that isolated β -components (dimerized constituting α -chains) were strongly fluorescent with a spectrum similar to that of collagen obtained from aged tissues. The occurrence of chain dimers can be also demonstrated by gel electrophoresis.

3.7. Collagen glycation *in vivo*

One has to keep in mind that *in vitro* interactions between aldehyde sugars and collagen polypeptide chains are run under much harsher conditions compared to the *in vivo* situation. However, *in vivo* there is much more time available for the glycation reaction to proceed. It is therefore not surprising that the *in vivo* glycation does not affect all the CNBr peptides equally as is more-or-less the situation *in vitro*; those which seemed most prone to the *in vitro* glycation reaction, i.e., $\alpha_1(\text{I})\text{CB}_6$ and $\alpha_2(\text{I})\text{CB}_{3,5}$ indeed seem to be subjects of the glycation reaction *in vivo*. In the $\alpha_1(\text{I})\text{CB}_6$ and $\alpha_2(\text{I})\text{CB}_{3,5}$ peptides both types of glycation products, i.e., pentosidine and

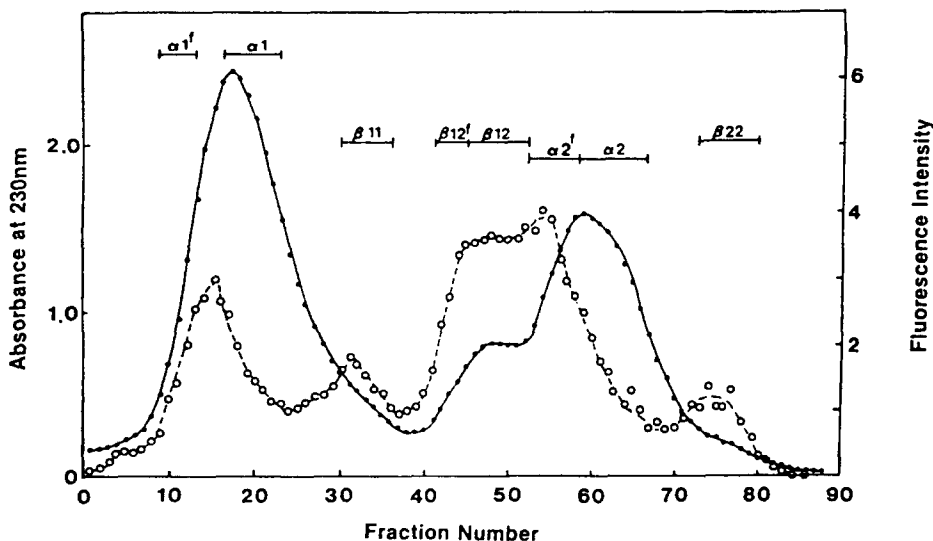

Fig. 10. CM-cellulose chromatogram of collagen chains. Elution monitored by absorbance (●) and by fluorescence intensity (○). Reprinted from Tanaka et al. [55] by permission of American Society for Biochemistry and Molecular Biology.

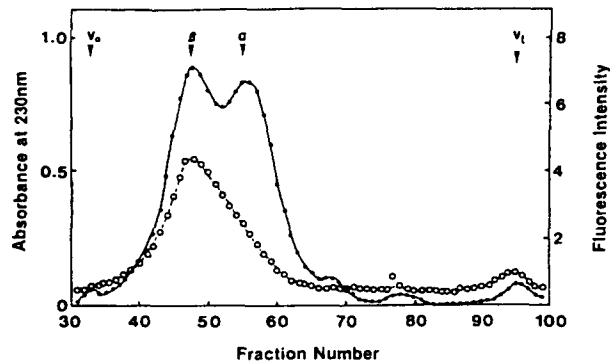

Fig. 11. Sepharose CL-6B gel permeation of the β_{12} fraction isolated by CM-cellulose chromatography (see Fig. 10). Reprinted from Tanaka et al. [55] by permission of American Society for Biochemistry and Molecular Biology.

non-pentosidine glycation products were found, there were no fluorophores present in peptides constituting fractions 1 and 4, i.e., in peptides $\alpha_2(\text{I})\text{CB}_2$, $\alpha_1(\text{I})\text{CB}_2$, $\alpha_1(\text{I})\text{CB}_5$, $\alpha_1(\text{I})\text{CB}_7$, $\alpha_1(\text{I})\text{CB}_8$ and very little if any pentosidine fluorescence was observed in the incomplete cleavage products eluting in fraction 4 (see Fig. 8).

In the paper of Tanaka et al. [55] it was further

shown that by glycation in vitro β_{11} , β_{12} and β_{22} components of collagen type I are formed (see also above). On the other hand we were unable to prove systematic occurrence of CNBr peptides with a higher molecular mass than about 60 000 (we have seen it in two cases only out of more than fifty). Because pentosidine (which is typically a cross-linking amino acid) should involve two polypeptide chains, our results strongly suggest that in vivo glycation mediated cross-linking occurs preferably at two places in the molecule, involving the $\alpha_1(\text{I})\text{CB}_6$ and $\alpha_2(\text{I})\text{CB}_{3,5}$ peptide. For sure the pentosidine related fluorescent compounds seem to have nothing in common with the CNBr cleavage resistant portion of the collagen molecule. On the other hand, however, the well documented polymerization of the parent collagen α -chains is likely to proceed through one big peptide (like those specified above) with another small peptide attached. In a preliminary quantitation (by peak area) of the CNBr peptides released, it was observed indeed that in preparations obtained from 18 months old animals, the peptide $\alpha_2(\text{I})\text{CB}_2$ (rel. mol. mass 2700) vanished nearly completely and at least one other ($\alpha_1(\text{I})\text{CB}_4$ rel. mol. mass 4400) was considerably decreased. On the other hand the area percentage of $\alpha_1(\text{I})\text{CB}_6$ (rel. mol. mass 17 400) increased from 13.92% to 17.09% between the preparations obtained from 12 and 18 months old animals. Similarly the peak of $\alpha_2(\text{I})\text{CB}_{3,5}$ showed a 2.71% increase. Further investigation is, however, needed to obtain a complete picture of collagen cross-linking through glycation products

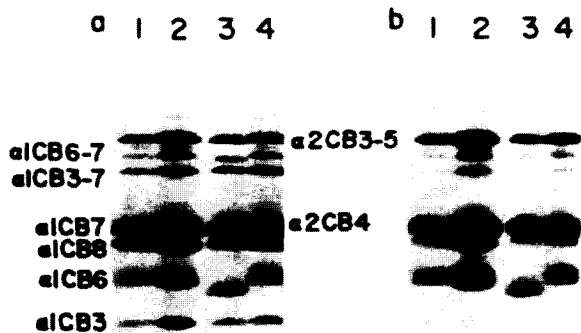

Fig. 12. SDS-PAGE of CNBr digests of tendon labeled for 1 day with [^{14}C]ribose, stained with Coomassie Blue (a) and an autoradiogram (b). Lane 1, 1-day labeled tendon; lane 2, acid extract of 1-day labeled tendon; lane 3, acid-extracted 1-day labeled tendon after pepsin treatment; lane 4, control for lane 3. Reprinted from Tanaka et al. [55] by permission of American Society for Biochemistry and Molecular Biology.

under different physiological conditions and with advancing age.

Reiser et al. [56] investigated preferential sites of glycation in $\alpha_1(\text{I})\text{CB}_3$ and $\alpha_2\text{CB}_{3,5}$ peptides. In case of the $\alpha_1(\text{I})\text{CB}_3$ peptide Lys-434 was preferred (from the five lysine residues present) and in the case of $\alpha_2\text{CB}_{3,5}$ peptide three residues (namely Lys-453, Lys-479 and Lys-924) from a total of 18 lysine residues and 1 hydroxylysine residue contained more than 80% of the glucose adducts in the peptide. These preferential glycation sites are highly conserved with aging. In our results some fluorophores were observable in fraction 2 containing the $\alpha_1(\text{I})\text{CB}_4$, $\alpha_1(\text{III})\text{CB}_2$, $\alpha_1(\text{III})\text{CB}_6$, $\alpha_1(\text{I})\text{CB}_3$ and $\alpha_1(\text{III})\text{CB}_4$ peptides. On the contrary to the non-pentosidine fluorescence present in peptides $\alpha_1(\text{I})\text{CB}_6$ and $\alpha_2(\text{I})\text{CB}_{3,5}$ the fluorescence exhibited 420 nm emission when excited at 375 nm which is slightly shorter than the parameters of fluorescence of advanced glycation products (375/440) [40]. It may be speculated that this fluorescence stems from further glycation of the Amadori products as shown with albumin glycation (Section 2.5.) [28].

The present discussion regards glycation adducts occurring in type I collagen. Pentosidine is believed to be present at least partly in the helical portion of the $\alpha_1(\text{I})\text{CB}_6$ peptide. On the contrary, in collagen type IV [37] nonenzymatic glycation affects mainly the non-collagenous domain (NC1) (Fig. 13).

3.8. Collagen–lipoperoxidation adducts

Though model compounds capable of forming collagen-adducts were proposed and characterized by luminescence parameters (see Table 1), no adequate separation methods indicating the presence of such adducts are available at the moment. The main problem here lies in the detectability (identification of different glycation and lipoperoxidation products by, e.g., luminescence parameters is difficult as long as they are very close in their excitation and emission wavelengths). Still the first attempts using fluorescence measurement at different excitation wavelengths seem indicative of the existence of fluorescent lipoperoxidation adducts in vivo which seem to accumulate in the connective tissue with age at different rate.

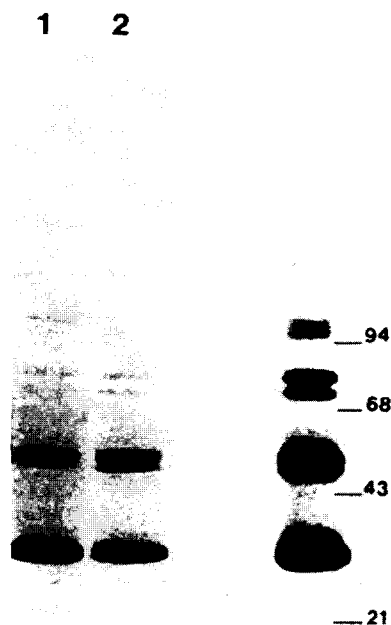

Fig. 13. SDS-PAGE analysis (left) of control (1) and glycated NC1 domain with $[6\text{-}^3\text{H}]$ glucose (2); right, fluorogram of line 2 of the previous gel. Reprinted from Tsilibary et al. [37] by permission of American Society for Biochemistry and Molecular Biology.

3.9. Separation of glycated adducts from physiologically occurring cross-links

Collagens are specific in that they contain both enzymatically and non-enzymatically derived cross-links. An analytical approach for such a mixture of compounds was devised by Andreassen and Oxlund [65]. The glucose incubated rat tail tendons were reduced with tritiated sodium borohydride for about 1 h, dialyzed against pH 4.0 buffer and hydrolyzed in 6 M HCl in the usual way. Upon ion-exchange chromatography using Beckman 120 C amino acid analyzer (see Robins et al. [66]) and stepped pH gradient the result seen in Fig. 14 was obtained.

Separation of glycated lysine and hydroxylysine using similar incubation procedure and similar ion-exchange chromatography (Beckman 120 B amino acid analyzer, using PA 28 resin eluted with 0.36 M citrate buffer pH 5.28 at 55°C) offered clearcut separation of tritiated glycated lysine and hydroxylysine from the parent amino acids [67]. This latter

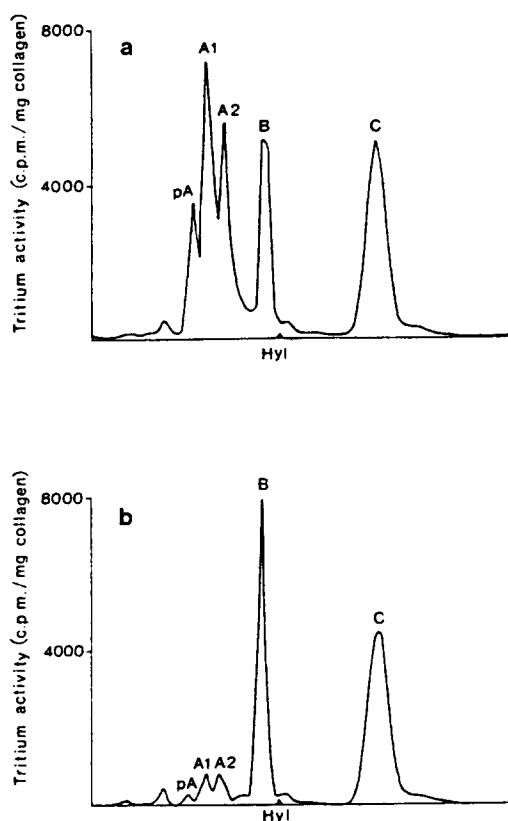

Fig. 14. Ion-exchange chromatograms of radioactive cross-links of rat tail tendon collagen after incubation in phosphate buffer with (a) and without (b) glucose for 12 days. Peaks were identified as glucosylhydroxylysine (pA), glucosyllysine (A1) and its acid degradation product (A2), hydroxylysineonorleucine (B) and histidinohydroxymerodesmosine (C). Reprinted from Andreassen and Oxlund [65] by permission of Springer.

paper is interesting in that it brings the first evidence about possible glycation of type II collagen. It also demonstrates an increased resistance of glycated collagen type I towards human polymorphonuclear leucocyte collagenase (as documented by SDS polyacrylamide gel electrophoresis and radioactivity detection).

To summarize all applications related to collagen glycation products exceeds clearly this analytically oriented review. A brief overview covering selected papers from the last seven years that contributed to the analytical techniques used to reveal the pathways of glycated collagen formation and their biological implications is summarized in Table 2.

4. Lens proteins

4.1. Sample solubilization and general

A lot of the glycation experiments with lens proteins are done with the soluble crystallins which are prepared in the following way, though the insoluble fraction (at least in our opinion) should represent the preferred subject of study when glycation mediated polymerization is to be attacked: the decapsulated lens is homogenized in 1.5 ml 0.2 M phosphate buffer, pH 7.4, in an ice bath, the suspension is centrifuged at 30 000 g for 30 min at 4°C and the supernatant is used as the soluble fraction. A portion of this preparation is filtered through a membrane filter (pore size 0.45 μm) and the filtrate is gel chromatographed on TSK G 3000 SW (0.45 × 60 column). Other separation media can be used for the gel permeation step as well (e.g., Sephacryl S 200 gel, TSK gel 3000 SW etc.). Also a number of variations of the homogenization buffer were described in the literature (e.g., 0.1 M Tris buffer pH 7.4 containing 0.5 M NaCl, 1 mM EDTA and 0.1% NaN₃, Ref. [79]). The procedure yields the so called high molecular mass protein (HMW and α, β and γ-crystallin fractions [80]. Other procedures involving small modifications can be found in the literature (see, e.g., [81]). A procedure for preparing soluble lens proteins (without isolating the α, β and γ crystallins) can be done for instance by homogenizing decapsulated lens in phosphate buffered saline (PBS) (pH 7.4) and centrifuging the homogenate at 18 000 g for 1 h at 4°C. The supernatant is removed and dialyzed against PBS at 4°C overnight. The remaining solution is described as soluble lens protein (crystallin mixture) [82].

4.2. Glycation adducts, carbamylated crystallins and products of oxidative modification

Electrophoretic examination of lens proteins is routinely done by the Laemmli [3] method and Coomassie Blue staining. When compared with molecular mass standards more intensive staining was observed with bands exhibiting molecular mass 108 000, 42 000 and 39 000 respectively. The quality of the separation is rather poor and therefore only semiquantitative comparison of diabetic and non-

Table 2
Separation procedures applied to collagen glycation products under different physiological and pathological conditions

Entity assayed	Source material and biological conditions	Method	Remark	Reference
N ^ε -Carboxymethyllysine	Diabetic glomerular basement membrane in mice	Amino acid chromatography after OPA derivatization (Hypersil ODS)		[68]
Amadori product (ε-hexoselysine)	Aging, effect of food regime	Boronate affinity chromatography (Glyco gel test kit)		[69]
Furoyl AGEs	Diabetic rats (MS/MS analysis)	Mass spectrometry	No FFI* detected	[70]
Fluorescent glycation products	Aging of intervertebral disc	SDS-PAGE, reversed-phase chromatography of molecular sieving, digestion with CNBr		[71]
Fluorescent glycation products, (350/440 and 300/360–370 nm)	Effect of combined glycation and oxidation	Gel permeation chromatography, SDS-PAGE. Digestion with CNBr.	Effect of fructose	[72]
Glucitolysine fluorescent products	Aging	SDS electrophoresis, amino acid analysis, separation of tryptic and CNBr peptides	Preparation of glucitolysine and glucitolhydroxylysine standards, α ₂ (1)CB _{3,5} and α ₁ (1)CB ₃ found as preferential	[56]
Glycation and glycosylation products	Aging, collagen type II, annulus fibrosus, articular cartilage	SDS-PAGE, molecular sieving, amino acid analysis		[38]
Pentosidine and pyridinoline	Lens capsule (collagen type IV)	HPLC of fluorescent compounds		[73]
Carboxymethyllysine, pentosidine, glycooxidation products, Amadori adducts	Effect of preglycation and presence of phosphate on glycooxidation product formation in vitro	GC/MS, SIM-GC/MS, RP-HPLC for pentosidine	in vitro study	[74]
AGEs glycooxidation products	Inhibition of the late stage of the Maillard reaction	SDS-PAGE	in vitro study	[75]
Autooxidation products	Corneal type I collagen, effect of transition metals (Cu, Fe)	SDS-PAGE molecular sieving	in vitro study	[76]
Fluorescent compounds K1 and K2, K3 and K4 not further specified. Non fluorescent adduct	Diabetic tissues	Molecular sieving, ion-exchange chromatography, reversed-phase chromatography	Differences between in vitro incubations with glucose and ribose	[77]
N ^ε -Carboxymethyllysine and N ^ε -Carboxymethylhydroxylysine	Human skin, aging	SIM-GC/MS		[78]

* FFI = (2-(2-furoyl)-4(5)-(2-furanyl)-1H-imidazole).

diabetic preparations is possible [83]. On the other hand it was reported that the overall proportion of lens proteins in the streptozotocin treated rats tissue is higher in diabetics as compared to controls (perhaps owing to the polymerized species which are more difficult to metabolize).

Investigation of the polymerization reactions resulting from the incubation with different sugars are frequently analyzed by using either gel permeation chromatography on TSK gel 2000 SW (7.5×600 mm) column coupled in series with a TSK gel 3000 SW (7.5×300 mm) or SDS Laemmli gel electrophoresis, as reported by Swamy et al. [84]. The results of 10 days incubation in PBS with 5 mg/ml protein and 5 mM sugars suggest that glycation increases with decreasing carbon chain of the sugar (triose>tetrose>pentose>hexose). Similar results are reported in Ref. [85].

Using bovine lenses (prenatal, newborn, adult, aged) Van Boekel et al. [86] accumulated evidence that all categories of crystallins are glycosylated though not to the same extent. Contrary to other studies van Boekel et al. [86] investigated early glycation products and were able to show that these products are derived mainly from γ crystallin. α -Crystallin, α A subunits seem to be glycosylated to a higher extent compared with the α B subunits (a number of gel permeation columns were used along with gel electrophoresis - AcA 34, Pharmacia-LKB, Superose 6, Pharmacia-LKB, Sephadex G 75, Pharmacia, Zorbax 450/250, Du Pont and TSK G 5000 PW preceded by a TSK guard column, Bio Rad). Chromatographic runs were evaluated routinely by measuring the luminescence at 370/440 nm. Samples were NaBH_4 reduced before analysis and separation was done in 0.1 M glycine-HCl buffer (pH 2.5). Other gel permeation media like Zorbax GF 450/GF 250 [87], Superdex columns, Sepharose 6B FPLC (Pharmacia, Uppsala) [88] are also applicable.

The differences in gel permeation methodology (mostly buffer composition variants) appear of practically negligible value for the results obtained [87,89]. A nice comparative study using glucose, galactose and glucosyl-6-phosphate and different modes of detection using Zorbax GF 450/GF 250 was reported in Ref. [87] (Fig. 15). Data for separating the polymerized species in the presence of 6 M urea can be also found in the literature [88].

In human lens proteins it is possible to detect not only the glycation adducts (fructoselysine) but also oxidation products of these adducts, namely N^ϵ -(carboxymethyl)lysine and 3-(N^ϵ -lysino)lactic acid [90–92]. This analysis is done by the GC-SIM technique after acid hydrolysis [90]. Lysine and carboxymethyllysine can be measured directly as their trifluoroacetyl methyl ester derivatives and fructoselysine is determined as the furosine derivative which is formed in the yield of about 40% from the parent compound during acid hydrolysis. The mass spectra of the trifluoroacetyl methyl esters of the compounds (m/z 320, 392 and 110 ions) are used for quantitation of lysine, carboxymethyl lysine and furosine respectively [90].

There is one point to keep in mind with respect to lens protein glycation. In streptozotocin treated rats (the most common model for diabetes) it is not only glucose that is elevated in the lens tissue. In the rat lens two additional phosphomonoesters, fructose-3-phosphate and sorbitol-3-phosphate are produced. Detailed data in this respect regarding also the presence and identification of other sugars can be found in Refs. [93–95].

Besides glycation adducts (obtained *in vitro* by incubating the crystallin sample with glucose, glucose-6-phosphate or ribose for about 10 days at 37°C) it is also possible to obtain carbamylated crystallins (by incubating α -crystallin with 25 mM sodium cyanate for about 7 days at 37°C) or to obtain oxidatively modified crystallins (by adding 0.1 mM FeSO_4 , 0.3 mM EDTA and 0.1 mM H_2O_2 and incubating the mixture at 37°C for about 4–19 h).

4.3. Adducts and polymerization reactions related to interactions with ascorbic acid

It is generally known that the normal lens tissue contains a higher level of ascorbic acid in comparison to glucose [96–98]. Therefore the idea that this may play a role in senile cataracts has been expressed already in 1985, followed by a lot of papers devoted to this subject.

In vitro cross-linking of lens crystallins proceeds rapidly in presence of ascorbic acid (ASA) and air [99–101]. The exclusion of oxygen from the reaction medium prevents cross-linking of crystallins by

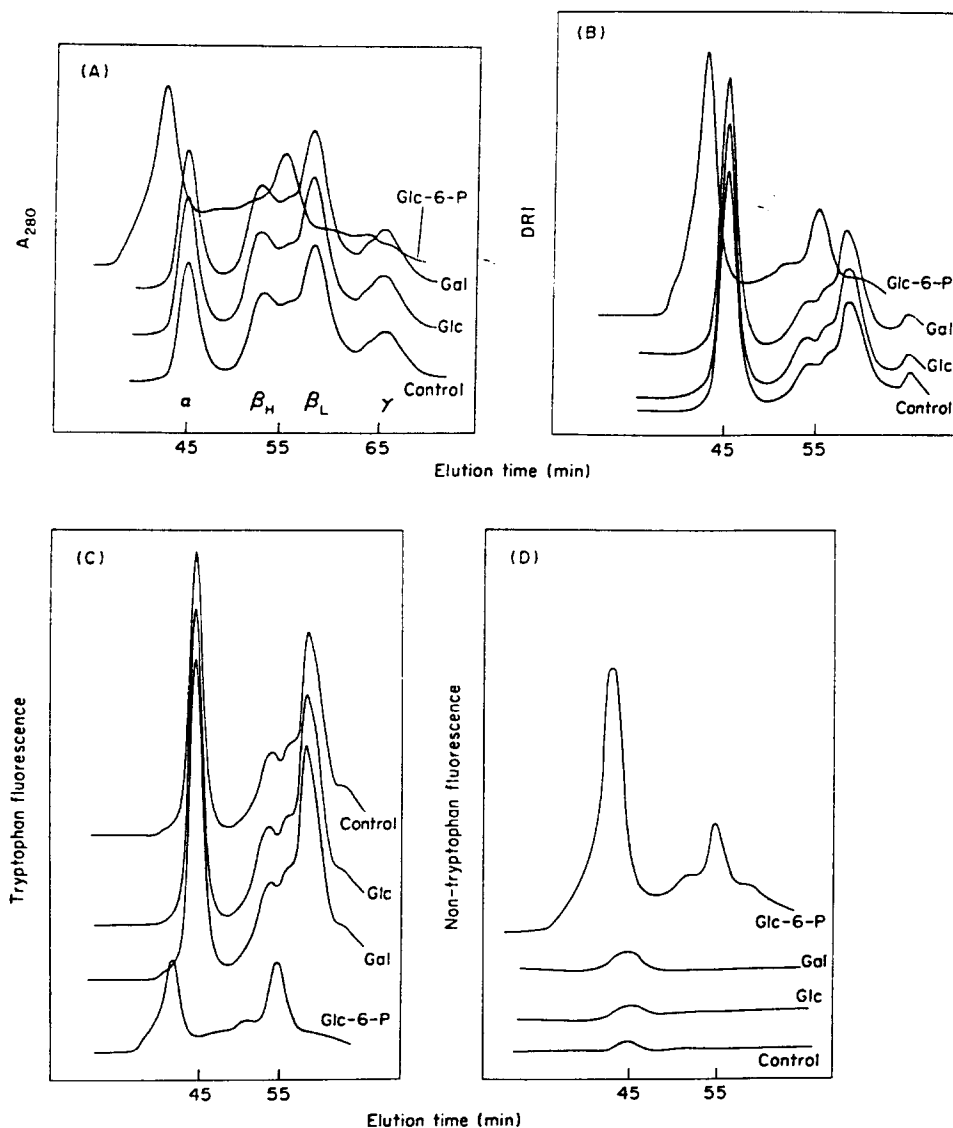

Fig. 15. Gel permeation chromatography of sugar-incubated calf lens crystallins, detecting by absorbance at 280 nm (A), differential refractive index detector (B), tryptophan fluorescence (290/340 nm) (C) and non-tryptophan fluorescence (370/440 nm) (D). Reprinted from van Boekel and Hoenders [87] by permission of Academic Press.

ASA, however lens proteins may undergo glycation with dehydroascorbic acid or diketogulonic acid even in the absence of oxygen. It is to be noted that these two sugar acids are direct oxidation products of ascorbic acid. Formation of pentosidine in lens proteins is mainly related to ascorbic acid level rather than to the direct interaction with, e.g., glucose.

A thorough investigation of the effect of ascorbic acid upon crystallin was reported by Prabhakaram and Ortwerth [102]. A brief outline of their procedure runs as follows: Purified γ -crystallin is iodinated with ^{125}I (carrier free), and chloramine T is added in Tris-HCl buffer pH 7.5. The reaction is allowed to continue for 1 min and is terminated by the addition of 1.0 mg of sodium metabisulfite.

Iodinated γ -crystallin is separated from unbound ^{125}I , and other reactants by passing through a Sephadex G-25 column and dialyzed extensively against 0.1 M phosphate buffer, pH 7.0, containing 1 mM DTPA (diethylenetriaminepentaacetic acid). In the next step 1 mg of this radioactively labeled γ -crystallin is added (i) crude lens extract, (ii) α -, β_{H} -, β_{L} - or γ -crystallin, again in 0.1 M phosphate buffer with 1 mM DTPA (pH 7.0). Glycation is initiated by the addition of 20 $\mu\text{mol/ml}$ ascorbic acid, the reaction mixture is sterilized by filtering and samples withdrawn in weekly intervals. Final evaluation is done by the Laemmli electrophoresis (detection by scanning the radioactivity of dried gels).

The other approach to reveal which crystallin type may undergo the ascorbic acid glycation reaction in vitro is boronate affinity chromatography (Affi Gel) which essentially followed the method of Perry et al. [103]. Briefly, lens proteins are reacted with ascorbic acid for 0–3 weeks, dialyzed overnight against deionized water and then applied to a boronate affinity column which has been pre-equilibrated with 0.25 M ammonium acetate buffer pH 8.5. The unbound proteins are eluted with the same buffer while the ascorbic acid adducts are released by applying the same buffer made 0.2 M with respect to sorbitol (absorbance at 280 nm was used for detection).

In SDS-PAGE Prabhakaram and Ortwerth [102] were able to demonstrate that dimers, polymers and high molecular mass aggregates are formed in vitro with the crude lens extract and α -crystallin; β_{H} - and β_{L} -crystallins are less reactive and no polymerization can be revealed with γ -crystallin which is ascribed to the low content of lysine in this crystallin fraction (Fig. 16).

Here the proof is based on directly assaying the lysine adducts. These adducts are, however, labile to acid hydrolysis (see our previous review-1); therefore they must be stabilized before analysis by, e.g., borohydride reduction and the very assay is done by amino acid analysis. This approach was shown to be applicable to both in vivo and in vitro experiments. Because stabilisation of the glycation adducts can be materialized through borohydride (borotritide) reduction, the protein bound radioactivity offers additional information about the glycation process.

In a study of Ortwerth et al. [104] it was shown that ascorbic acid incorporation into lens crystallin is 6–7 times more rapid than a similar reaction with glucose.

Observation of fluorescence spectra adds to information that can be obtained by following either the electrophoretic or chromatographic patterns of post-translationally modified crystallins [105]. Due to the presence of tryptophan in both α and γ -crystallin the fluorescence spectra (excitation 280, emission around 335) show only a single fluorescence band. Upon fructation and using $\Delta\lambda=40$ nm difference between the excitation and emission wavelengths it is possible to see in the emission spectrum another small band (at ~ 385 nm). This to our knowledge is the first attempt at using synchronous fluorescence spectroscopy for identifying structural changes in proteins; it clearly demonstrates the possibility to distinguish between the natural tryptophan/tyrosine fluorescence and fluorescence related to the glycation adducts (very likely due to pentosidine formation). This technique, however, has not yet been used for protein fragments, perhaps owing to the fact that most of the authors investigating non-enzymatic post-translational alterations in proteins rely mainly upon routine gel electrophoresis, which is unsuitable for synchronous fluorescence hyphenation. HPLC–Synchronous fluorescence spectroscopy, however, appears a new tool within the hyphenated techniques family which may contribute considerably to our understanding of how proteins in the body are modified by non-enzymatic processes.

4.4. Pentosidine related cross-linking

The high level of ascorbate in human lens led to attempts to investigate whether or not the only so far identified product of sugar–protein reaction, pentosidine, can be found in this tissue. Incubation of crystallins with ascorbate and its oxidation products, dehydroascorbate and 2,3-diketogulonate leads progressively to the formation of pentosidine cross-links in the presence of oxygen. Under nitrogen, however, only 2,3-diketogulonate or xylosone are formed. A high correlation between pentosidine cross-links and the degree of lens pigmentation was noted in cataractous lenses [106]. Pentosidine was found

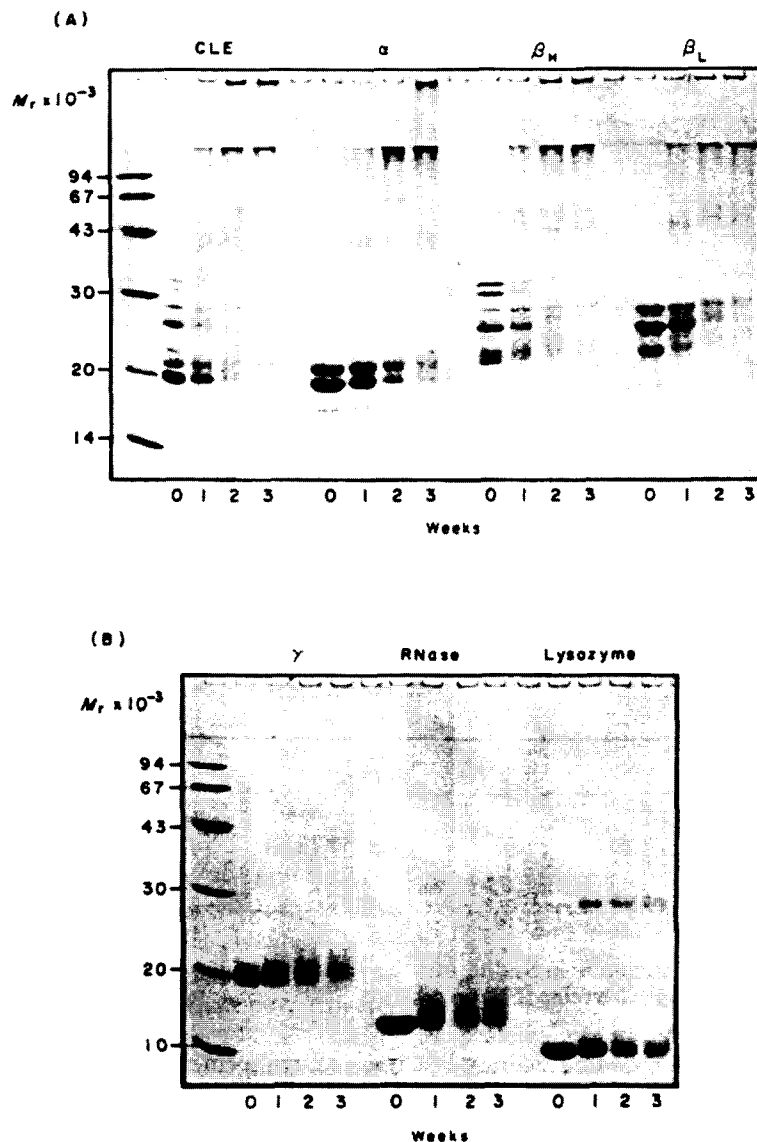

Fig. 16. SDS-PAGE analysis of crystallins during incubation with ascorbic acid over a period of 3 weeks. Plate A, crude lens extract (CLE), α -crystallin, β_H -crystallin and β_L -crystallin; Plate B, γ -crystallin, RNase and lysozyme. Reprinted from Prabhakaram and Ortweh [102] by permission of Academic Press.

primarily associated with the α -crystallin fractions (300 000–5 000 000 rel. mol. mass).

As far as separation procedures is concerned, only standard methods of protein analysis were applied (for review of pentosidine assay see our previous paper [1]).

Some idea about the distribution of pentosidine in

between individual crystallin types can be obtained from Fig. 17. For analysis cataractous and control lenses were gently shaken to separate the cortex from the nucleus, the nuclei were homogenized in 10 mM Tris-HCl (pH 7.5) containing 2 mM EGTA. The homogenate was spun at 30 000 g for 10 min and the supernatants were fractionated on agarose A-5 m

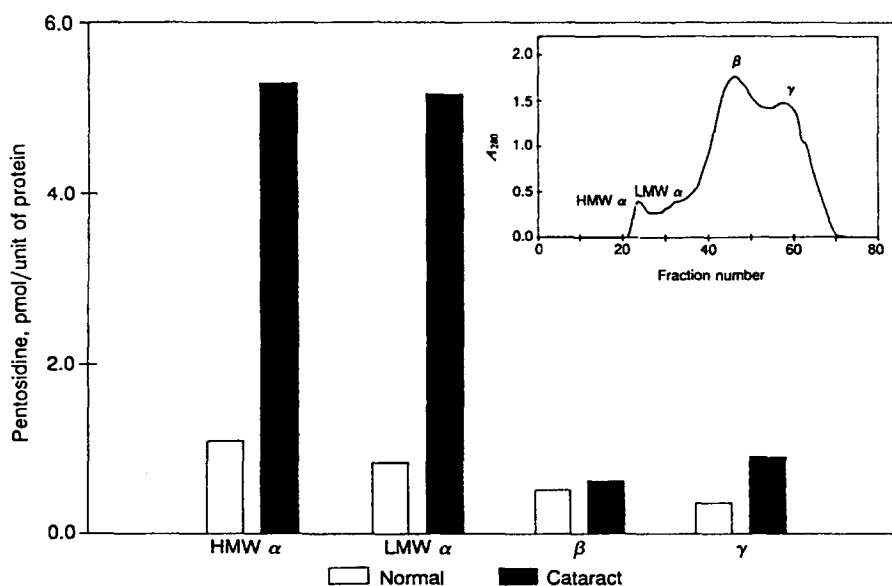

Fig. 17. Distribution of pentosidine in individual crystallin subfractions of normal and cataractous lenses separated on a 5 m agarose A column. HMW, high molecular mass; LMW, low molecular mass. Reprinted from Nagaraj et al. [106] with permission.

(1.5×43 cm column) using the same buffer (i.e., 10 mM Tris pH 7.5) as the eluent. Fractions of 1.1 ml were collected at a flow-rate of 0.3 ml/min. Fractions corresponding to high molecular mass α -crystallin (75 000–800 000), low molecular mass α -crystallin (300 000–800 000), β -crystallin (30 000–150 000) and γ -crystallin (20 000) were pooled, dialyzed against 3000 ml of water over 24 h and subjected to hydrolysis and pentosidine assay. Evidence for increased pentosidine levels in diabetic cataract using C_{18} reversed-phase column (Supelco 25 cm×4.6 mm) with a complex, stepped acetonitrile gradient (5–50% acetonitrile made 0.1% with respect to heptafluorobutyric acid) was reported by Lyons et al. [107].

Autooxidation of ascorbic acid adducts leads to N^{ϵ} -(carboxymethyl)lysine which can be assayed by GC amino acid analysis [108,109].

4.5. Fructose derived adducts

In γ -crystallin fructation leads to structural destabilization of monomeric crystallin; on the contrary in α -crystallin it leads to structural stabilization increasing the affinity of this protein to multimeric aggregation (mostly dimers of rel. mol. mass

40 000–42 000 are formed by intermolecular cross-linking of both αA and αB crystallin monomers as revealed by gel electrophoresis in 12.5% gel). These opposite effects are ascribed to altering the charge balances within the molecule (for details see [105]). Methods used for revealing the fructose modified crystallins don't differ from the analytical methods used for other sugars. However, the effect of this modification compared to reactions with, e.g., glucose or ascorbic acid is considerably different.

4.6. Adducts with methylglyoxal

Methylglyoxal is an endogenous metabolite that increases in diabetes and like other $-CHO$ or $=CO$ bearing compounds is believed to be involved in some long-term complications of this disease.

Simple polyacrylamide gel electrophoresis using crystallins previously incubated with methylglyoxal (pre-separated by Sephacryl S300HR, yielding crystallin α , β_H , β_L and γ) can be used to demonstrate this interaction in vitro. The samples (individual fractions from the Sephacryl separation) were boiled in 63 mM Tris buffer pH 6.8 containing 2% w/v SDS, 5% mercaptoethanol, 10% glycerol and 0.01% Bromphenol Blue for 5 min prior to electrophoresis.

Next the separation was materialized in 12.5% gel (5% stacking gel) at 40 mA per gel. The results are shown in Fig. 18, where both α - and γ -crystallins show an apparent increase in molecular mass from approx. 20 000 to 29 000 and the presence of polymerized crystallins (about 45 000–55 000 rel. mol. mass) can be traced. This increase is non-specific, i.e., it occurs in all crystallin fractions separated. This, however, does not mean that such generalized reaction occurs *in vivo* where probably only the more exposed lysine residues will be involved in the modification [110].

4.7. Acetylated crystallins

Another post-translational modification of crystallins is the acetylation of lysines induced by aspirin. It was postulated that the reactivity of lysyl residues and the possible inhibition of deleterious

reactions by acetylation may be of particular importance in the development of diabetic cataract. It has already been shown 10 years ago that pre- or concurrent incubation of lens crystallins with aspirin can limit the effectiveness of carbamylating and glycosylating reagents [111–113].

Lens crystallin preparation for the acetylation experiments is done more-or-less in the standard way [114]. Gel permeation chromatography is done using Sephadex G-200 (Pharmacia, Piscataway, NJ, USA). There is a number of the extraction conditions described in the literature which all can lead to acceptable results – Ref. [106]. As expected the fractionation gave four fractions, namely α -, β_H -, β_L - and γ -crystallins. The α -fraction (150 $\mu\text{g}/\text{ml}$) was incubated with 100 mM aspirin in 0.2 M Tris-HCl, pH 7.6, with 0.05% NaN_3 at 37°C for various times.

After incubation the samples were desalted to

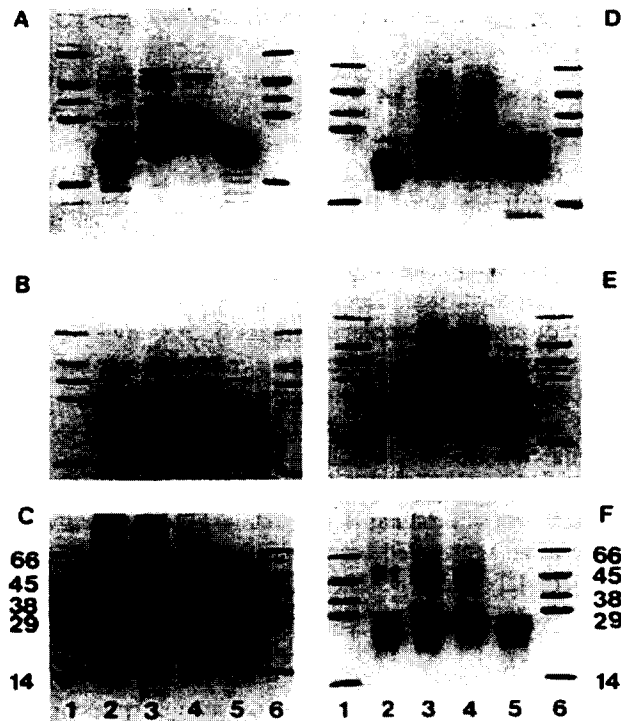

Fig. 18. SDS-PAGE of (A) unmodified bovine crystallins, (B) bovine crystallins incubated in buffer for 7 days, (C) bovine crystallins incubated in 5 mM methylglyoxal for 7 days, (D) unmodified human crystallins, (E) human crystallins incubated in buffer for 7 days, (F) human crystallins incubated in methylglyoxal for 7 days. Lanes: (2) α , (3) β_H , (4) β_L , (5) γ . Molecular mass standards were run in lanes (1) and (6). Reprinted from Riley and Harding [110] with permission.

remove excess aspirin and by possible by products and the purified acetylated crystallins were separated by making use of a 0.46×25 cm (Vydac C₁₈ column, Alltech, Deerfield, IL) with a linear gradient of 5–50% CH₃CN in water made 0.1% with respect to trifluoroacetic acid over a period of 60 min. The separation yielded two main subfractions, i.e., αA and αB crystallins (Fig. 19).

Location of the modified lysines in the crystallin molecule was achieved by analyzing enzymatic (pepsin, chymotrypsin) digests. Peptides generated by the enzymatic digestion were separated by reversed-phase chromatography using a C₁₈ column and a gradient of 5–40% acetonitrile in water (both 0.1% with respect to trifluoroacetic acid over 60 min)

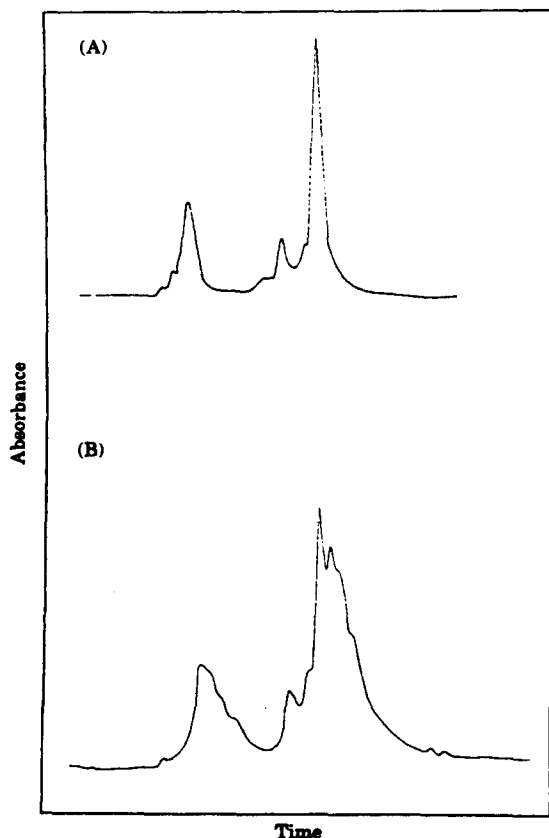

Fig. 19. Reversed-phase HPLC analysis of α -crystallins showing the separation into α B (first peak) and α A (second and third peaks). (A) Before incubation; (B) after incubation with aspirin. Reprinted from Hasan et al. [114] by permission of Academic Press.

[114]. The modified and unmodified peptides were collected in the same fraction; the acetylated peptides eluted just after their unmodified counterparts. Fractions were vacuum dried and used for FAB mass spectral analysis. It is worth noting that in these experiments trypsin can not be used because it cleaves C-terminal to lysine but does not cleave the same bond if acetylated lysine is involved.

4.8. Glycation of lens membrane proteins

The crude preparations of lens membrane proteins [115] exhibits the 350/430–450 nm fluorescence typical for advanced glycation products which is age and diabetes dependent; however diabetic conditions are capable of increasing this fluorescence far beyond the advanced age group level. No attempts have been published so far to attribute this fluorescence to particular protein fractions obtained (e.g., by gel permeation chromatography). On the other hand glycation products can be also found in the lens capsule (the evidence is based on the detection of glycosyl-lysine adduct after sodium borotritide reduction and amino acid analysis) [116–120].

5. Lipid peroxy radicals and dityrosine crosslinking

When α -crystallin from the bovine lens is incubated with the lipid peroxy radicals generated by incubation of linoleic acid-13-monohydroperoxide or phosphatidylcholine with methemoglobin a blue, non-tryptophan fluorescence of at least two kinds of fluorophores, stable and unstable on borohydride treatment is produced [121]. This treatment leads to distinct polymerization of the α -crystallin protein with a concomitant appearance of a distinct 298/388 nm fluorescence. Polymerization can be clearly documented by standard Laemmli SDS–polyacrylamide gel electrophoresis (15% with 4% stacking gel). If the polymerized product is hydrolyzed and assayed for amino acids present (ion-exchange chromatography, stepped citrate buffer gradient pH 3.3, 4.0, 4.9 followed by an alkaline wash) no additional peaks are visible with the UV detection; however, if instead of the regular ninhydrin detection the eluate is evaluated by measuring fluorescence at 298/388 nm

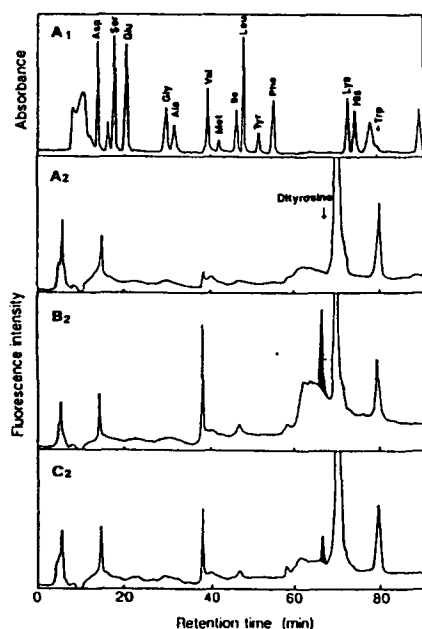

Fig. 20. Amino acid analysis of α -crystallin modified with none (A), linoleic acid 13-monohydroperoxide/methemoglobin (B) and hydrogen peroxide/horseradish peroxidase. Detection by ninhydrin coloration (1) and fluorescence intensity at 285–410 nm (2). Reprinted from Kikugawa et al. [121] with permission.

the picture shown in Fig. 20 is obtained. The dark peak was, on the basis of its comigration with dityrosine standard, ascribed to this amino acid. It was also demonstrated in model experiments that in this way also other proteins can yield dityrosine upon acid hydrolysis.

6. Glycation of other proteins

Though originally reported for long-lived proteins only, it is evident from the current literature that any protein can be glycated (or perhaps subject to other non-enzymatic post-translational modification) *in vivo*. *In vivo* modifications always face the problem of fishing out the glycated species from the tissue. It appears that phenylboronate activity chromatography is the routine first step (sometimes also ConA affinity

separations are used). *In vitro*, the first step is incubation of the particular protein species with an appropriate sugar (or other modifying compound). While some 15 years ago it was assumed that non-enzymatic glycation generally lead to protein polymerization (at least in the advanced stage of the reaction), it is well documented now that monotopical reactions take place as well. Moreover, some proteins (at least Cu,Zn superoxide dismutase, see Ref. [140]) can even be fragmented. The biological function of the protein is usually impaired but exceptions exist as well: e.g., glycated trypsin is not only more resistant towards denaturation but also has a higher proteolytic activity. Conformational alterations were newly demonstrated with laminin.

In vivo, usually only some of the available lysine and/or arginine residues are modified which reflects milder *in vivo* conditions and the limitations resulting from the conformational availability of different $-NH_2$ groups.

The general strategy may follow the scheme shown in Fig. 21. It just repeats what has already been said at the beginning of this review. The separation techniques used are very diverse and should be modified from case to case (see Tables 3–5 for a survey of proteins the glycation of which has been studied).

In clinically relevant cases so far not all authors use separation techniques to reveal the presence of a glycated species; they are tempted to use immunochemical approaches, ELISA or a combination with some separation procedure. The attempts to find glycation markers enabling a direct assay of glycated (or otherwise modified) species in different tissues were reviewed in a preceding paper [1]. So far, no simple, generally accepted methodology is available.

Regarding detection the 370/440 nm fluorescence has been widely adopted as a proof for the presence of advanced glycation end products. Regarding the detection of hydrolytically stable marker adducts see our previous communication [1]. So far very little if anything at all is known about non-fluorescent adducts, the presence of which is anticipated. On the other hand reductive labeling of the early glycation products with sodium borotritide or *in vitro* incubation of either 3H or ^{14}C labeled glucose is of considerable help in finding the resulting products.

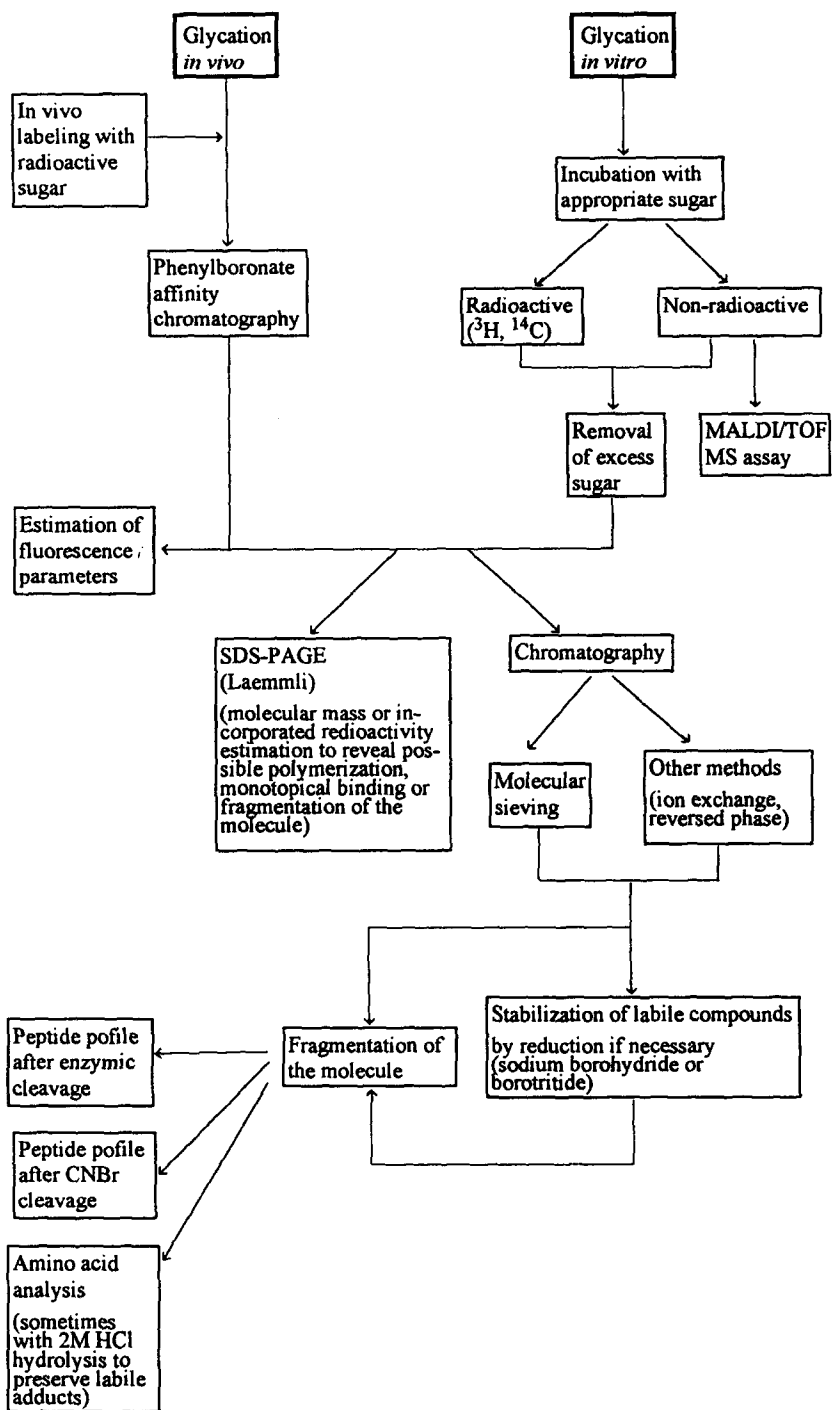

Fig. 21. Suggested general strategy for sample enrichment and separation of glycosylated products in vivo and in vitro.

Table 3
Separation techniques used for glycosylated brain proteins

Protein modified	Source	Assay method	Comment	Reference
Proteins of neurons	Hippocampus	Anti-AGE antibody	Recognizes N ^ε -(carboxymethyl)lysine	[122]
Proteins of c neurofilaments	Brain	SDS-PAGE and immunoblotting		[123]
Proteins of c neurofilaments		HPLC of released peptides (C18); SDS-PAGE and immunoblotting	Determination of preferentially glycosylated lysines in the molecule	[124]
Proteins of neurons	Hippocampus	SDS-PAGE and immunoblotting (ELISA)	Alzheimer disease	[125]
Calmodulin, platelet proteins, glycohaemoglobin	Bovine brain	<i>m</i> -aminophenylboronate agarose, ELISA, fructosamine assay	Aging effects	[126]
Actin	Brain	2D-PAGE	Experimental diabetes	[127]
Calmodulin	Brain	HPLC of CNBr peptides (C ₁₈), SDS-PAGE (³ H glucose)		[128]
Cytoskeletal proteins, serum albumin	Brain	Glucitolysine (amino acid analysis, PTTC method), 2 M HCl used for hydrolysis to prevent destruction	Also galactitol lysine used for spiking	[129]

Table 4
Separation techniques used for glycated diverse serum proteins

Protein modified	Source	Assay method	Comment	Reference
α_1 -Antitrypsin	Serum	SDS-PAGE	Superoxide radicals generated during non-enzymatic glycation, fragmentation of protein by glucose/ Cu^{2+} incubation	[130]
Immunoglobulin M	Serum	Tryptic digest, <i>m</i> -aminophenylboronate chromatography, fructosamine assay, ConA Sepharose chromatography, ^3H labeled glucose	In vitro glycation	[131]
Antithrombin III		SDS-PAGE, phenylboronate chromatography, CNBr fragments, separation on Sephadex G-50, Heparin affinity chromatography	In vitro glycation	[132]
Early glycation products of serum albumin, hair keratin	Serum	Agarose- <i>m</i> -aminophenylboronate affinity chromatography, SDS-PAGE	Effect on metabolism	[133]
Fibrinogen	Serum	SDS-PAGE, <i>m</i> -aminophenylboronate chromatography	Alloxan induced diabetes	[134]
β_2 -microglobulin	Serum, urine, amyloid tissue	Sephadex G-75 chromatography, ELISA, SDS-PAGE blotting	Uremic patients	[135]
Early glycation products of serum albumin, hair keratin	Serum, hair	Derivatization with phenylhydrazine	Diabetic rats, deglycation study with aminoguanidine or hydrazine	[136]
Amadori glucose adducts of serum	Serum	SDS-PAGE, Affi-gel Blue Phenylboronate albumin affinity chromatography	Effect on collagen gene expression	[137]
Nerve growth factor and immunoglobulin G	Plasma	Boronate affinity chromatography, SDS-PAGE, protein labeled with ^{125}I or ^{131}I	Permeation across blood-nerve barrier, protein half lives	[138]
Insulin-like growth factor binding protein	Serum	SDS-PAGE, nitrocellulose blotting. Fructosamine assay, proteins labeled with ^{125}I	Effect of glycation upon binding of the insulin-like growth factor	[139]
Cu/Zn Superoxide dismutase	Erythrocytes	Phenylboronate affinity chromatography (Glyco gel B)	Diabetic patients	[140]
Immunoglobulin G	Serum	Sephacryl S0-300, SDS-PAGE (Phast System); Sephadex G-75, DEAE cellulose for preparation of pure immunoglobulin and its constituting chains		[141]

Table 5
Separation techniques used for glycosylated other proteins (examples)

Protein modified	Source	Assay method	Comment	Reference
Alcohol dehydrogenase	Horse and human liver	Tryptic peptides, Affi Gel 601 after borotritide reduction, Mono S cation-exchange chromatography, RP-HPLC (HiPore RP-304)	In vivo glycation	[142]
Ovalbumin	Commercial product	PAGE	Acetylated and succinylated species	[143]
Cu,Zn-Superoxide dismutase	Recombinant human Cu,Zn superoxide dismutase	SDS-PAGE, electroblotting	Fragmentation of the protein by glycation in the presence of oxygen	[144]
EC-Superoxide dismutase	Commercial product (human protein)	RP-HPLC (C_{18}) of chymotryptic peptides, Phenylboronate affinity chromatography	Reduction of the affinity to heparin	[145]
Creatine kinase	Heart, skeletal muscle	Con A affinity chromatography, Protein Pak Glass 300 SW, agarose gel electrophoresis	Differences between skeletal muscle and heart tissue protein	[146]
Na,K-ATPase	Kidneys	SDS-PAGE (^{14}C labeled glucose), Dowex 50-X8 chromatography, HPLC on TSK 3000 column	Inhibition of enzymic activity in the absence of ATP	[147]
Alcohol dehydrogenase	Liver	Phenylboronate chromatography, PTC of <i>N</i> -(1-deoxyhexitoly) amino acids on Partisil ODS-3	Glycation in vivo	[148]
Laminin	Engelbreth-Holm-Swarm tumor	SDS-PAGE (3H glucose)	Glycation in vitro, changes in molecular shape	[149]
Histones	Calf thymus	Acidic urea PAGE, amino acid analysis by two-dimensional TLC	No glycation of histones in vivo was revealed	[150]
Histones	Calf thymus	GC/MS of acid hydrolysate	FFI	[151]
Histones, nucleotide	Rate liver	SDS-PAGE (^{14}C -glucose used)	Impairing of chromatin function	[152]
Lysozyme, Lactoferrin	Chicken lysozyme	SDS-PAGE, CNBr lysozyme fragments	Recombinant proteins, decreased antibacterial activity	[153]
Proteins of mesangial cells	Mesangial cells	SDS-PAGE, Western blotting	Stimulation of mesangial cells with glycosylated proteins (diabetic mice)	[154]
Aspartate aminotransferase	Rat liver (cytosol)	Isoelectric focusing		[155]
Trypsin		SDS-PAGE	Increase in enzymic activity	[156]

7. Conclusions

It is difficult indeed to outline a system of separation methods used for proteins modified by glycation or by other carbonyl moiety possessing compounds (for possible strategy see Fig. 21). In general, gel permeation chromatography and gel electrophoresis are used for revealing the polymerized products. Boronate affinity chromatography serves the accumulation of modified protein solutes bearing vicinal hydroxy groups. Detection is done either by fluorescence (370/440 nm is supposed to be indicative for advanced glycation products which apparently do not represent a single compound) while for the only so far well characterized glycation derived cross-linking product detection at 335/385 nm is applied. Immunochemical detection techniques if available to the researcher are used as well. Apparently not only polymerizing (bitopical) reactions occur in the body; quite a few, so far poorly understood, modifications also occur *in vivo*. However, some (or even the majority of them) may be non-fluorescent and, consequently, difficult to detect. In any case post-translational reactions of this type may have profound physiological consequences and represent a challenging area for research.

Acknowledgements

This work was supported by the Grant Agency of the Czech Republic, grant No. 303/96/K128.

References

- [1] Z. Deyl, I. Mikšík, *J. Chromatogr. B* (in press).
- [2] J.T. Wu, Ming-Chieh Tu, Ping Zhung, *J. Clin. Lab. Anal.* 10 (1996) 21.
- [3] U.K. Laemmli, *Nature* 227 (1970) 680.
- [4] K. Weber, M. Osborn, *J. Biol. Chem.* 224 (1969) 4406.
- [5] Z. Hodný, I. Syrový, *J. Biochem. Biophys. Methods* 26 (1993) 273.
- [6] Z. Hodný, R. Stružinský, Z. Deyl, *J. Chromatogr.* 578 (1992) 53.
- [7] T. Myint, S. Hoshi, T. Ookawara, N. Miyazawa, K. Suzuki, N. Taniguchi, *Biochim. Biophys. Acta* 1272 (1995) 73.
- [8] Y. Wada, *J. Mass Spectrom.* 31 (1996) 263.
- [9] F.N. Ziyadeh, M.P. Cohen, *Mol. Cell. Biochem.* 125 (1993) 19.
- [10] P.J. Beisswenger, J.C. Healy, E.K. Shultz, *Metabolism* 42 (1993) 989.
- [11] S. Nakatani, Y. Kato, M. Nasu, S. Fujita, Y. Katayama, *Bunseki Kagaku* 41 (1992) 387.
- [12] G. Cavallo-Perin, A. Chiambretti, V. Calefato, M. Tomalino, G. Cecchini, G. Gruden, G. Pagano, *Clin. Nephrol.* 38 (1992) 9.
- [13] G. Pagano, A. Chiambretti, V. Calefato, M. Tomalino, G. Cecchini, A. Breuno, P. Cavallo-Perin, *Acta Diabetol.* 28 (1991) 39.
- [14] M.P. Cohen, E. Hud, *J. Immunol. Methods* 122 (1989) 279.
- [15] I. Cohen, D. Burk, R.J. Fullerton, A. Veis, D. Green, *Thrombosis Res.* 55 (1989) 341.
- [16] T. Sakurai, M. Takanashi, S. Tsuchiya, *Chem. Pharm. Bull.* 40 (1992) 1653.
- [17] A.C. Silver, E. Lamb, W.R. Cattell, A.B.St.J. Dawney, *Clin. Chim. Acta* 202 (1991) 11.
- [18] M.P. Cohen, *Diabetologia* 34 (1991) 766.
- [19] K. Shima, N. Ito, F. Abe, M. Hirota, M. Yano, Y. Yamato, T. Uchida, K. Noguchi, *Diabetologia* 31 (1988) 627.
- [20] G.E. Austin, R.H. Mullins, L.G. Morin, *Clin. Chim.* 33 (1987) 2220.
- [21] P. Vidal, E. Nielsen, B.S. Welinder, *J. Chromatogr.* 573 (1992) 201.
- [22] T. Koyama, K.-I. Terauchi, *J. Chromatogr. B* 679 (1996) 31.
- [23] M. Du Bois, K.A. Gilles, J.K. Hamilton, P.A. Rebers, F. Smith, *Anal. Chem.* 280 (1956) 350.
- [24] A. Kumar, T.N. Pattabiraman, *Ind. J. Biochem. Biophys.* 25 (1988) 703.
- [25] A. Kallner, *Scan. J. Lab. Clin. Med.* 50 (1990) 763.
- [26] N. Kobayashi, N. Ogashara, T. Sakoguchi, M. Kimura, K. Taniuchi, A. Matsuoka, *Clin. Chem.* 36 (1990) 65.
- [27] E. Hurd, M.P. Cohen, *Clin. Chim. Acta* 185 (1989) 157.
- [28] G. Suárez, J. Maturana, A.L. Oronsky, C. Raventós-Suárez, *Biochim. Biophys. Acta* 1075 (1991) 12.
- [29] P.C. Smith, C. Wang, *Biochem. Pharmacol.* 44 (1992) 1661.
- [30] Y. Hayashi, A. Morikawa, M. Makino, *Clin. Chim. Acta* 190 (1990) 93.
- [31] J.P. Bohny, R.C. Feldhoff, *Biochem. Pharmacol.* 43 (1992) 1829.
- [32] J.P. Bohny, M.L. Fonda, R.C. Feldhoff, *FEBS Lett.* 298 (1992) 266.
- [33] D.J. Prockop, K.I. Kivirikko, *Annu. Rev. Biochem.* 64 (1995) 403.
- [34] V.M. Monnier, M. Glomb, A. Geganish, D.R. Sell, *Diabetes* 45 (Suppl. 3) (1996) S67.
- [35] I. Mikšík, Z. Deyl, *J. Gerontol.* 46 (1991) B111.
- [36] S. Lertisir, K. Fujimoto, T. Miyazawa, *Biochim. Biophys. Acta* 1245 (1995) 278.
- [37] E.C. Tsilibary, A.S. Choronis, L.A. Reger, R.M. Wohlheuter, L.T. Furcht, *J. Biol. Chem.* 263 (1988) 4302.
- [38] C. Yang, S. Mosler, H. Reu, B. Baetage, H. Notbohm, P.K. Müller, *Matrix Biol.* 14 (1994) 643.
- [39] K.M. Reiser, *Proc. Soc. Exp. Biol. Med.* 196 (1991) 17.
- [40] Z. Deyl, I. Mikšík, J. Zicha, D. Jelínková, *Anal. Chim. Acta* (in press).
- [41] J. Novotná, Z. Deyl, I. Mikšík, *J. Chromatogr. B* 681 (1996) 77.

- [42] Z. Deyl, J. Novotná, I. Mikšík, D. Jelínková, M. Uhrová, M. Suchánek, *J. Chromatogr. B* 689 (1997) 181.
- [43] I. Mikšík, J. Novotná, M. Uhrová, D. Jelínková, Z. Deyl, *J. Chromatogr. A* 772 (1997) 213.
- [44] P.P. Fietzek, K. Kühn, *Int. Rev. Connect. Tissue Res.* 7 (1976) 1.
- [45] M. van der Rest, H.P.J. Bennet, S. Solomon, F.H. Glorieux, *Biochem. J.* 191 (1980) 253.
- [46] M. van der Rest, P.P. Fietzek, *Eur. J. Biochem.* 125 (1982) 491.
- [47] E.J. Miller, R.K. Rhodes, D.K. Furuto, *Collagen Rel. Res.* 3 (1983) 79.
- [48] E.J. Miller, D.K. Furuto, A.J. Narkates, *Anal. Biochem.* 196 (1991) 54.
- [49] Z. Deyl, M. Adam, *J. Chromatogr.* 488 (1989) 161.
- [50] S. Ayad, R. Boot-Hanford, M.J. Humphries, K.E. Kadler, A. Shuttleworth, *The Extracellular Matrix Facts Book*, Academic Press, London, 1994.
- [51] P.G. Scott, A. Veis, *Connect. Tiss. Res.* 4 (1976) 107.
- [52] E.J. Miller, E.H. Epstein, K.A. Piez, *Biochem. Biophys. Res. Commun.* 42 (1971) 1027.
- [53] M. Van der Rest, H.P.J. Bennet, S. Solomon, F.H. Glorieux, *Biochem. J.* 191 (1990) 253.
- [54] J.F. Bateman, P. Mascara, D. Chan, W.G. Cole, *Anal. Biochem.* 154 (1986) 338.
- [55] S. Tanaka, G. Avigad, E.F. Eikenberry, B. Brodsky, *J. Biol. Chem.* 263 (1988) 17650.
- [56] K.M. Reiser, M.A. Amigable, J.A. Last, *J. Biol. Chem.* 267 (1992) 24207.
- [57] D.R. Sell, V.M. Monnier, *J. Biol. Chem.* 264 (1989) 21597.
- [58] D.G. Dyer, J.A. Dunn, S.R. Thorpe, K.E. Bailie, T.J. Lyons, D.R. McCance, J.W. Baynes, *J. Clin. Invest.* 91 (1993) 2463.
- [59] R.H. Nagaraj, M. Prabhakaram, B.J. Ortwerth, V.M. Monnier, *Diabetes* 43 (1994) 580.
- [60] J.T. Wu, M.-C. Tu, P. Zhung, *J. Clin. Lab. Anal.* 10 (1996) 21.
- [61] D.R. Sell, V.M. Monnier, *Connect. Tiss. Res.* 19 (1989) 77.
- [62] F. Hayase, H. Hinuma, M. Asano, H. Kato, S. Arai, *Biosci. Biotech. Biochem.* 58 (1994) 1936.
- [63] P. Odetti, M.A. Pronzato, G. Noberasco, L. Cosso, N. Traverso, D. Cottalasso, U.M. Marinari, *Lab. Invest.* 70 (1994) 61.
- [64] R. Zamora, F.J. Hidalgo, *Biochim. Biophys. Acta* 1258 (1995) 319.
- [65] T.T. Andreassen, H. Oxlund, *Diabetologia* 28 (1985) 687.
- [66] S.P. Robins, M. Shimokomaki, A.J. Bailey, *Biochem. J.* 131 (1973) 771.
- [67] A.J. Perejda, E.J. Zaragoza, E. Eriksen, J. Uitto, *Collagen Rel. Res.* 4 (1984) 427.
- [68] M. Weininger, Z. Xi, B. Lubec, S. Szalay, H. Höger, G. Lubec, *Nephron* 62 (1992) 80.
- [69] I. Mikšík, R. Stružinský, Z. Deyl, *Mechanisms of Aging and Development* 57 (1991) 163.
- [70] A. Lapolla, C. Gerhardinger, E. Ghezzi, R. Saraglia, A. Sturaro, G. Crepaldi, D. Fedelle, P. Traldi, *Biochim. Biophys. Acta* 1033 (1990) 13.
- [71] S.E. Hormel, D.R. Eyre, *Biochim. Biophys. Acta* 1078 (1991) 243.
- [72] E. Fujimori, *Biochim. Biophys. Acta* 998 (1989) 105.
- [73] A.J. Bailey, T.J. Sims, N.C. Avery, C.A. Miles, *Biochem. J.* 296 (1993) 489.
- [74] M.C. Wells-Knecht, S.R. Thorpe, J.W. Baynes, *Biochemistry* 34 (1995) 15134.
- [75] Min-Xin Tu, K.J. Wells-Knecht, J.A. Blackledge, T.J. Lyons, S.R. Thorpe, J.W. Baynes, *Diabetes* 43 (1994) 676.
- [76] K.V. Chace, R. Carubelli, R.E. Nordquist, *Arch. Biochem. Biophys.* 288 (1991) 473.
- [77] A.J. Bailey, T.J. Sims, N.C. Avery, E.P. Halligan, *Biochem. J.* 305 (1995) 385.
- [78] J.A. Dunn, D.R. McChance, S.R. Thorpe, T.J. Lyons, J.W. Baynes, *Biochemistry* 30 (1991) 1205.
- [79] M. Luthra, D. Balasubramanian, *J. Biol. Chem.* 268 (1993) 177.
- [80] A. Kamei, *Chem. Pharm. Bull.* 40 (1992) 2787.
- [81] A. Kamei, *Jpn. J. Ophthalmol.* 34 (1990) 216.
- [82] M.S. Swamy, C. Tsai, A. Abraham, E.C. Abraham, *Exp. Eye Res.* 56 (1993) 177.
- [83] A. Yarat, Z. Uguz, A. Üstünel, N. Emekli, *Glycoconjugate J.* 12 (1995) 622.
- [84] M.S. Swamy, C. Tsai, A. Abraham, E.C. Abraham, *Exp. Eye Res.* 56 (1993) 177.
- [85] A. Kamei, *Chem. Pharm. Bull.* 40 (1992) 2787.
- [86] M.A.M. van Boekel, H. Hoenders, *Biochim. Biophys. Acta* 1159 (1992) 99.
- [87] M.A.M. van Boekel, H.J. Hoenders, *Exp. Eye Res.* 53 (1991) 89.
- [88] M.A.M. van Boekel, S.E.A. Hoogakker, J.J. Harding, W.W. de Jong, *Ophthalmic Res.* 28(suppl 1) (1996) 32.
- [89] H. Nagaraj, V.M. Monnier, *Biochim. Biophys. Acta* 1116 (1992) 34.
- [90] J.A. Dunn, J.S. Patrick, S.R. Thorpe, J.W. Baynes, *Biochemistry* 28 (1989) 9464.
- [91] J.W. Baynes, M.U. Ahmed, C.I. Fisher, C.J. Hull, T.L. Lehman, N.G. Watkins, S.R. Thorpe, *Dev. Food Sci.* 13 (1986) 421.
- [92] M.U. Ahmed, J.A. Dunn, M.D. Walla, S.R. Thorpe, J.W. Baynes, *J. Biol. Chem.* 263 (1988) 8816.
- [93] H. Knecht, M.S. Feather, J.W. Baynes, *Arch. Biochem. Biophys.* 294 (1992) 130.
- [94] S. Lal, B.S. Szwegold, A.H. Taylor, W.C. Randall, F. Kappler, K. Wells-Knecht, J.W. Baynes, T.R. Brown, *Arch. Biochem. Biophys.* 318 (1995) 191.
- [95] S. Lal, B.S. Szwegold, A.H. Taylor, W.C. Randall, F. Kappler, T.R. Brown, *Invest. Ophthalmol. Visual Sci.* 36 (1995) 969.
- [96] O.A. Bessey, *J. Biol. Chem.* 103 (1993) 687.
- [97] C.A. Long, *Biochemist's Handbook*, Van Nostrand, NJ, USA.
- [98] H.L. Kern, S.L. Zolot, *Curr. Eye Res.* 6 (1987) 885.
- [99] B.J. Ortwerth, M.S. Feather, P.R. Olesen, *Exp. Eye Res.* 47 (1988) 155.
- [100] B.J. Ortwerth, P.R. Olesen, *Biochim. Biophys. Acta* 956 (1988) 10.
- [101] S.H. Slight, M.S. Feather, B.J. Ortwerth, *Biochim. Biophys. Acta* 1038 (1990) 367.
- [102] M. Prabhakaram, B.J. Ortwerth, *Exp. Eye Res.* 55 (1992) 451.

- [103] R.E. Perry, M.S. Swamy, E.C. Abraham, *Exp. Eye Res.* 44 (1987) 269.
- [104] B.J. Ortwerth, S.H. Slight, M. Prabhakaram, Y. Sun, J.B. Smith, *Biochim. Biophys. Acta* 1117 (1992) 207.
- [105] M. Luthra, D. Balasubramanian, *J. Biol. Chem.* 268 (1993) 18119.
- [106] R.H. Nagaraj, D.R. Sell, M. Prabhakaram, B.J. Ortwerth, V.M. Monnier, *Proc. Natl. Acad. Sci. USA* 88 (1991) 10257.
- [107] T.J. Lyons, G. Silvestri, J.A. Dunn, D.G. Dyer, J.W. Baynes, *Diabetes* 40 (1991) 1010.
- [108] S.H. Slight, M. Prabhakaram, D.B. Shin, M.S. Feather, B.J. Ortwerth, *Biochim. Biophys. Acta* 1117 (1992) 199.
- [109] M.U. Ahmed, S.R. Thorpe, J.W. Baynes, *J. Biol. Chem.* 261 (1986) 4889.
- [110] M.L. Riley, J.J. Harding, *Biochim. Biophys. Acta* 1270 (1995) 36.
- [111] R. Huby, J.J. Harding, *Exp. Eye Res.* 47 (1988) 53.
- [112] G.B. Rao, E. Cotlier, *Biochem. Biophys. Res. Commun.* 151 (1988) 991.
- [113] M.S. Swamy, E.C. Abraham, *Invest. Ophthalmol. Vis. Sci.* 30 (1989) 1120.
- [114] A. Hasan, J.B. Smith, W. Qin, D.L. Smith, *Exp. Eye Res.* 57 (1993) 29.
- [115] M.S. Swamy, E.C. Abraham, *Curr. Eye Res.* 11 (1992) 833.
- [116] R.E. Perry, M.S. Swamy, E.C. Abraham, *Exp. Eye Res.* 44 (1987) 269.
- [117] M. Prabhakaram, B.J. Ortwerth, *Biochim. Biophys. Res. Commun.* 185 (1992) 496.
- [118] G. Chandrasekher, R.J. Cenedella, *Exp. Eye Res.* 60 (1995) 707.
- [119] G. Chandrasekher, R.J. Cenedella, *Exp. Eye Res.* 57 (1993) 737.
- [120] B.J. Ortwerth, P.R. Olsen, *Exp. Eye Res.* 55 (1992) 777.
- [121] K. Kigukawa, T. Kato, M. Beppu, A. Hayasaka, *Biochim. Biophys. Acta* 1096 (1991) 108.
- [122] T. Kimura, J. Takamatsu, K. Ikeda, A. Kondo, T. Miyakawa, S. Horiuchi, *Neurosci. Lett.* 208 (1996) 53.
- [123] M.A. Smith, S.L. Siedlak, P.L. Richey, R.H. Nagaraj, A. Elhammer, G. Perry, *Brain Res.* 717 (1996) 99.
- [124] M.D. Ledesma, P. Bonay, J. Avila, *J. Neurochem.* 65 (1995) 1658.
- [125] J.J. Li, M. Surini, S. Catsicas, E. Kawashima, C. Bouras, *Neurobiol. Aging* 16 (1995) 69.
- [126] A. Muruganandam, G.J. Romsa, R.J. Thibert, R.M.-C. Cheung, T.F. Draisey, B. Mutus, *Clin. Chem.* 39 (1993) 815.
- [127] C. Pekiner, N.A. Cullum, J.N. Hughes, A.J. Hargreaves, J. Mahon, I.F. Casson, W.G. McLean, *J. Neurochem.* 61 (1993) 436.
- [128] R.A. Kowluru, D.B. Heidorn, S.P. Edmondson, M.W. Bitensky, A. Kowluru, N.W. Downer, T.W. Whaley, J. Trehwella, *Biochemistry* 28 (1989) 2220.
- [129] M.R. Brown, T.J. Keith, H.R. Knoll, *Neurochem. Int.* 21 (1992) 177.
- [130] P.K. Hall, R.C. Roberts, *Biochim. Biophys. Acta* 1121 (1992) 325.
- [131] T. Menini, A. Gugliucci, A.J.C. Stahl, *Clin. Chim. Acta* 213 (1992) 23.
- [132] T. Sakurai, J.-P. Brissel, H.F. Bunn, *Biochim. Biophys. Acta* 964 (1988) 340.
- [133] M.W.C. Hatton, M. Richardson, P.D. Winocour, *J. Theor. Biol.* 161 (1993) 481.
- [134] M.W.C. Hatton, S. Southward, B. Ross-Ouellet, M. Richardson, P.D. Winocour, *J. Lab. Clin. Med.* 121 (1993) 588.
- [135] T. Niwa, T. Katsuzaki, T. Momoi, T. Miyazaki, H. Ogawa, A. Saito, S. Miyazaki, K. Maeda, N. Tatemichi, Y. Takei, *Kidney Int.* 49 (1996) 861.
- [136] K. Kobayashi, K. Yoshimoto, K. Hirauchi, K. Uchida, *Life Sci.* 53 (1993) 291.
- [137] M.P. Cohen, F.N. Ziyadeh, *Kidney Int.* 45 (1994) 475.
- [138] J.F. Poduslo, G.L. Curran, *Mol. Brain Res.* 23 (1994) 157.
- [139] A.M. Cortizo, J.J. Gagliardino, *J. Endocrinol.* 131 (1991) 33.
- [140] N. Taniguchi, K. Arai, N. Kinoshita, *Methods. Enzymol.* 179 (1989) 570.
- [141] R. Dolhofer-Bliesener, K.D. Gerbitz, *Biol. Chem. Hoppe-Seyler* 371 (1990) 693.
- [142] B.H. Shilton, D.J. Walton, *J. Biol. Chem.* 266 (1991) 5587.
- [143] P.P. Batra, M.A. Roebuck, D. Uetrecht, *J. Protein Chem.* 9 (1990) 37.
- [144] T. Ookawara, N. Kawamura, Y. Kitagawa, N. Taniguchi, *J. Biol. Chem.* 267 (1992) 18505.
- [145] T. Adachi, H. Ohta, K. Hayashi, K. Hirano, S. Marklund, *Free Radical Biol. Med.* 13 (1992) 205.
- [146] M.R. Langlois, J.R. Delanghe, M.L. De Buyzere, G.G. Leroux-Roels, *Clin. Chim. Acta* 211 (1992) 83.
- [147] M.H. Garner, A. Bahador, G. Sachs, *J. Biol. Chem.* 265 (1990) 15058.
- [148] J.D. McPherson, B.H. Shilton, D.J. Walton, *Biochem. Biophys. Res. Commun.* 152 (1988) 711.
- [149] A.S. Charonis, L.A. Reger, J.E. Dege, K. Kouzi-Koliakos, L.T. Furcht, R.M. Wohlheuter, E.C. Tsilibary, *Diabetes* 39 (1990) 807.
- [150] A. Lakatos, K. Jobst, *Acta Biochim. Biophys. Hung.* 24 (1989) 355.
- [151] M.M. Liebich, E. Gesele, C. Wirth, J. Wöll, K. Jobst, A. Lakatos, *Biol. Mass Spectrom.* 22 (1993) 121.
- [152] T. Tarkka, N. Yli-Mäyry, R.-M. Mannermaa, K. Majamaa, J. Oikarinen, *Biochim. Biophys. Acta* 1180 (1993) 294.
- [153] Y.M. Li, A.X. Tan, H. Vlassara, *Nature Med.* 1 (1995) 1057.
- [154] O.G. Pankewycz, Jing-Xin Guan, W.K. Bolton, A. Gomes, J.F. Benedict, *Kidney Int.* 46 (1994) 748.
- [155] M. Okada, H. Harima, Y. Hosoi, A. Sogo, *J. Nutr. Sci. Vitaminol.* 39 (1993) 311.
- [156] Y. Kato, T. Matsuda, R. Nakamura, *Biosci. Biotech. Biochem.* 57 (1993) 1.
- [157] F. Frantzen, *J. Chromatogr. B* 699 (1997) 269–286.